







## WORLDWIDE

---

Pramac group operates through a proprietary distribution network of 15 branches covering the whole world.

### BUSINESS AREAS

POWER  
MATERIAL HANDLING EQUIPMENT  
SERVICE&PARTS  
PRAMAC RACING TEAM

PRAMAC history starts in 1966, when the Campinoti family founded L'Europea, a construction equipment company focused mainly in the Italian market. From then onwards PRAMAC has been expanding its activity in the energy and material handling sector, continuously growing on a global base with a wide and flexible product range to satisfy customers' energy needs in the world.







Since 1966 the company has been developing, manufacturing and selling from its Italian plant, a complete range of handling products aiming to satisfy any requirement expressed by Customers. The highly experienced personnel, the fully integrated production processes (from sheet metal to the finished product) and the on-going development of our trucks ensure that the entire range of machines delivers top quality build and performance. From light duty to most intense applications, the extreme care and dedication to innovation, guarantee that the entire range of machines comply with all applicable safety regulations. Through the network of Pramac branches we directly provide customers with the highest level of assistance during the entire supply process, from sales advice to after-sales support. Quality, innovation and reliability: these are the criteria that lead our team towards its final objective, Customer satisfaction!

The strategic objective of final customer satisfaction can only be reached if the quality of the products being offered is high. This is what the PR INDUSTRIAL group assumes for its production philosophy. The continuous improvement of all company processes, formulated with absolute respect for the environment and the specialized training of its personnel are part of the Total Quality programme which the company supports. We believe in and we promote our own real Culture for Quality with respect for the environment and regarding all specific standards. A concrete testimony of our commitment is the European and Extra-European certificates obtained by the company at a group level.





## SERVICE & PARTS

---

The after sales service supports our customers at every stage of the professional relationship, with availability of the full range of spare parts and components and a highly trained professional after sales team, answering requests worldwide. We ensure a quick service, taking advantage of our worldwide approved service network. Our website - [www.pramacparts.com](http://www.pramacparts.com) - is the powerful tool to support every after market aspects.

Following registration process, you will have access to a wide range of information.

Our portal provides detailed documentation and useful supports like:

- Product exploded drawings
- User manuals;
- Maintenance programs;
- Technical training activities;
- Service network point locator;
- Additional technical documentation;
- S&P catalogues and pricelist.

EXPERIENCE AND  
TECHNOLOGY TO DEVELOP  
TAILORED SOLUTIONS

OUR **SOLUTIONS**  
TO YOUR NEEDS



Our main objective is the complete customer satisfaction. This is possible only because we hardly work to provide best solutions to fulfill each and every customer need. This is the reason why we have created a product line dedicated to special solutions, providing customers with our vast professional experience focused on analyzing every single requirement. Indeed, this line integrates the high quality levels of our standard production line with the flexibility and versatility of custom made products.





Here the list of possible customized modifications that we can offer.  
In case you may need further modifications, please, contact our local sales network.

#### **HPT (GS/B - Mr Hydro/X/I excluded)**

- Forks width: from 350mm to 800mm
- Forks length: from 500mm to 2.000mm
- Frame galvanization of standard HPT
- Coil carrier
- ATEX certification

#### **SCALES (GS/P Stainless steel excluded)**

- Forks width: from 450mm to 800mm
- Forks length: from 500mm to 2.000mm
- ATEX certification

#### **HX 10M - HIGH LIFT PALLET TRUCK**

- Forks length: from 700mm to 2.000mm
- Forks width: from 470mm to 680mm
- Frame galvanization
- Manual brake
- ATEX certification

#### **HX 10E - HIGH LIFT PALLET TRUCK**

- Forks length: from 700mm to 2.000mm
- Forks width: from 470mm to 680mm
- Frame galvanization
- Auto leveling system \*
- Battery charger built in \*
- PLUS version with battery indicator
- ATEX certification

#### **CX 14 - EPT**

- Forks width: from 350mm to 685mm
- Forks length: from 500mm to 2.000mm
- Frame galvanization
- Load back rest

#### **QX - EPT (double lifting excluded)**

- Forks width: from 420mm to 680mm
- Forks length: from 800mm to 2.000mm
- Weighting system
- Kit for cold storage (max. -20°C)
- Frame galvanization
- Load back rest
- ATEX certification

#### **TX - STACKERS**

- Legs and forks width: from 500mm to 800mm
- Forks length: from 800mm to 1.150mm
- Max lifting height reduction
- ATEX certification
- Forks thickness reduction
- FEM forks
- PLUS version

#### **RX - STACKERS**

- Legs and forks width: from 500mm to 800mm
- Forks length: from 500mm to 1150mm
- Max lifting height reduction/meter or fraction
- ATEX certification
- FEM forks

#### **GX - STACKERS**

- Legs and forks width: from 500mm to 800mm
- Forks length: from 500mm to 1.150mm
- Max lifting height reduction / meter or fraction
- ATEX certification
- Forks thickness reduction
- FEM forks
- Straddle version

#### **TX STRADDLE - STACKERS**

- Useful width for pallets (B2) up to 1.500mm
- Forks length: from 500mm to 1.500mm
- Max lifting height reduction
- TX12 Straddle version
- ATEX certification

#### **LX - STACKERS**

- Legs and forks width: from 500mm to 800mm
- Forks length: from 800mm to 1.150mm
- Max lifting height reduction
- Kit for cold storage
- Straddle version
- ATEX certification
- Forks thickness reduction
- FEM forks

\* Models with a working width (b5) of 680mm

# PRODUCT RANGE

## Techno-polymer hand pallet trucks



**I-TON  
I-NOX**  
Capacity (t): 0.7 - 1.0

pag. 14

## Manual Trucks

### Hand Pallet Trucks



**GS  
BASIC**  
Capacity (t): 2.2

pag. 18

**GS  
PRO**  
Capacity (t): 2.5 - 3.0

pag. 18

**GS  
SPECIAL**  
Capacity (t): 2.0 - 3.0

pag. 18

**GS  
PREMIUM**  
Capacity (t): 2.5

pag. 18

**GS  
SILENCE**  
Capacity (t): 2.0

pag. 18



**GS  
MISTER  
HYDRO**  
Capacity (t): 2.5

pag. 20

## Scales

**GS/P25  
PX20**  
Capacity (t): 2.0 - 2.5

pag. 22



## High Lift Pallet Trucks



**HX10M**  
Capacity (t): 1.0

pag. 24

**HX10E**  
Capacity (t): 1.0

pag. 24

## Electric Pallet Trucks



**CX12**  
Capacity (t): 1.2

pag. 28

**CX14**  
Capacity (t): 1.4

pag. 28



**QX18  
QX20**  
Capacity (t): 1.8 - 2.0

pag. 30

**QX20DL**  
Capacity (t): 2.0

pag. 30

## Electric Pallet Trucks



**QX20P**  
Capacity (t): 2.0

pag. 32



**QX22**  
Capacity (t): 2.2

pag. 32

## Stackers

### Manual Stackers



**MX**  
Lifting height (m): 1.6  
Capacity (t): 0.5 - 1.0

pag. 36

### Semi-Electric Stackers



**TX  
TX STRADDLE**  
Lifting height (m): 3.5  
Capacity (t): 1.0 - 1.2

pag. 38

## Electric Stackers



**RX**  
Lifting height (m): 1.6  
Capacity (t): 1.0

pag. 38



**GX BASIC**  
Lifting height (m): 3.5  
Capacity (t): 1.2

pag. 42



**GX EVO**  
Lifting height (m): 3.5  
Capacity (t): 1.2

pag. 42

**GX EVO 12/29  
FREE LIFT**  
Lifting height (m): 2.9  
Capacity (t): 1.2

pag. 42



**LX 12-16 DUPLEX  
LX 14 TRIPLEX**  
Lifting height (m): 5.0  
Capacity (t): 1.2 - 1.6

pag. 44

### Residual Lifting Capacity

pag. 46





## TECHNO-POLYMER HAND PALLET TRUCKS

---

We are the only handling system manufacturer in the world introducing an innovative hand pallet truck made of non-metallic material. I-ton represents a real revolution making easier handling materials with respect for people, goods, work and environment. The use of a fiber glass reinforced techno-polymer compound, ensures some benefits in terms of lightness, maneuverability, noise level, environmental impact and cleanness.

# I-TON

## I-NOX



I-ton is the only pallet truck in the world made of non-metallic material. The new techno-polymer compound, based on modern technologies, is highly rigid and offers some important benefits:

- It is light
- It doesn't deform permanently
- It can be used in a broad temperature range
- It preserves its surface characteristics even when it is exposed to external corrosion agents

## I-NOX



Rustproof, hygienic, clean



### SAFE ENTRY OF THE ROLLERS

The integrated slide in the frame allows a safe entry of forks inside the pallet, reducing impact against rollers and related wear.



### QUICK LIFT FORKS

Maximum forks elevation can be reached with a limited number of strokes, reducing operator's effort and lifting work time.



### ERGONOMIC TILLER

The innovative tiller design helps operations with one hand only, ensuring a very solid tiller grip.



### ERGONOMIC TILLER

Ergonomic 3 positioning lever at the touch of a finger

- 1 lifting
- 2 neutral
- 3 descent

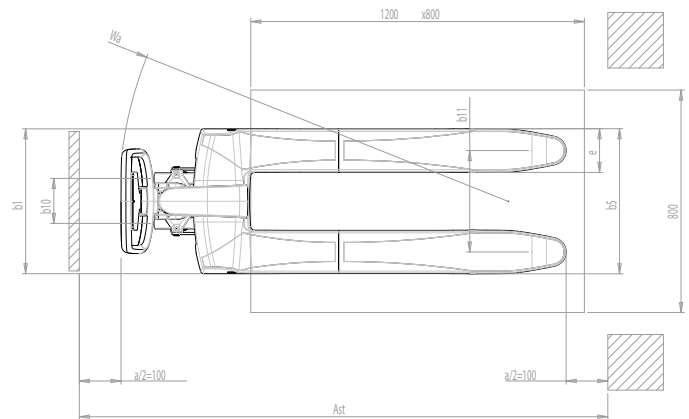
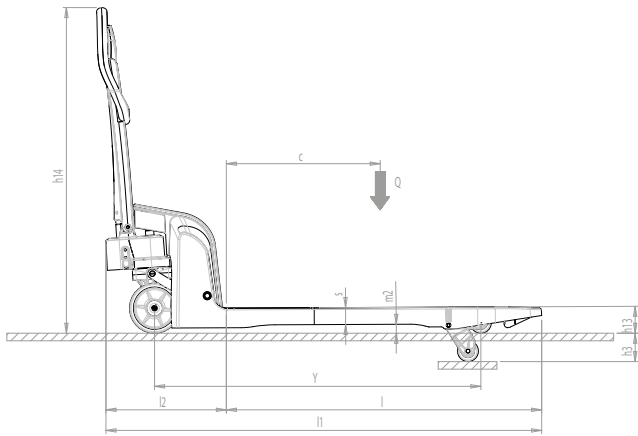

## I-TON VALUES

- **Ergonomic for people**

I-ton is light, quiet and has great maneuverability, making easier operator worklife, even for non professional users.

- **Ergonomic of handling goods**

I-ton guarantees quality and efficiency, assuring no corrosion, no rust and no contamination.

- **Ergonomic for work**

It is the hand pallet truck fitting to the widest range of applications, easy to be used by all the operators, guaranteeing a valuable improvement of productivity.

- **Ergonomic for the environment**

The material used for I-ton and the productive process guarantee fewer CO2 emissions during its life cycle, at the end of which it can be easily disassembled and recycled.

## I-NOX

Stainless steel components replace the carbon steel ones of the standard version, also lubricants suitable for food contact and low temperature oils are used, making I-ton the ideal solution to operate in clean environments, where hygiene and extreme corrosion resistance are of the utmost importance, such as:

- Cold store environments
- Wet conditions
- In the presence of acid or saline solutions
- Sterile environments

I-nox has ideal features to work in environments such as:

- Harbours
- Chemical industry
- Food industry, also in meat and fish processing
- Fruit & Vegetables markets
- Pharmaceutical industry
- Health care field

DESCRIPTION					
1.2	MODEL		I-ton S2-S4	I-nox S2-S4	
1.3	DRIVE		MANUAL	MANUAL	
1.4	OPERATOR TYPE		PEDESTRIAN	PEDESTRIAN	
1.5	LOAD CAPACITY	Q	kg	1000	700
1.6	LOAD CENTRE DISTANCE	c	mm	600	600
1.8	LOAD DISTANCE, CENTRE OF DRIVE AXLE TO FORK	x	mm	925	925
1.9	WHEEL BASE	y	mm	1182	1182
WEIGHTS					
2.1	SERVICE WEIGHT		kg	37-38	37-38
2.2	AXLE LOAD LADEN, FRONT/REAR		kg	300/737-738	218/519-520
2.3	AXLE LOAD UNLADEN, FRONT/REAR		kg	25/12-13	25/12-13
TYRES/CHASSIS					
3.1	TYRES			N-P/P	N-P/P
3.2	TYRE SIZE, FRONT (Ø x width)			180x40	180x40
3.3	TYRE SIZE, REAR (Ø x width)			75x80-60x60	75x80-60x60
3.4	SIDE WHEELS (Ø x width)			-	-
3.5	WHEELS, NUMBER (x=DRIVEN) FRONT/REAR			2/2-2/4	2/2-2/4
3.6	TREAD, FRONT	b10	mm	160	160
3.7	TREAD, REAR	b11	mm	365	365
DIMENSIONS					
4.4	LIFT	h3	mm	115	115
4.9	HEIGHT OF TILLER IN DRIVE POSITION MIN/MAX	h14	mm	615/1175	615/1175
4.15	HEIGHT, LOWERED	h13	mm	85	85
4.19	OVERALL LENGTH	l1	mm	1575	1575
4.20	LENGTH TO FACE OF FORKS	l2	mm	425	425
4.21	OVERALL WIDTH	b1	mm	520	520
4.22	FORK DIMENSIONS	s/e/l	mm	60/155/1150	60/155/1150
4.25	DISTANCE BETWEEN FORK ARMS	b5	mm	520	520
4.32	GROUND CLEARANCE, CENTRE OF WHEEL BASE	m2	mm	25	25
4.33	AISLE WIDTH FOR PALLETS 1000x1200 CROSSWISE	Ast	mm	1644	1644
4.34	AISLE WIDTH FOR PALLETS 800x1200 LENGTHWISE	Ast	mm	1844	1844
4.35	TURNING RADIUS	Wa	mm	1369	1369
PERFORMANCE DATA					
5.2	LIFT SPEED, LADEN/UNLADEN		strokes	9/9	9/9
5.3	LOWERING SPEED, LADEN/UNLADEN		m/s	0,05/0,02	0,05/0,02

G = Rubber, N = Nylon, P = Polyurethane, A = Steel, NE = Nylon extra







## MANUAL TRUCKS

---

The manual trucks range, produced in Italy, offers a complete series of ideal tools for handling pallets of any size. The range is made up of reliable products of high quality with a three-year warranty. Lifter by Pramac products are available in a wide range of models, with possible customisations based on specific final users requirements, offering tailor made solutions designed by the internal R&D department.

# GS

## GS BASIC GS PRO, GS SPECIAL GS PREMIUM, GS SILENCE

### GS BASIC

The GS basic pallet truck is the model of access to the range of Lifter hand pallet trucks with which it shares reliability and solidity. Available with fork length 800 and 1.150 mm.

### GS PRO, SPECIAL \*

The GS pro pallet truck is equipped as a standard with a start and exit roller and a more ergonomic handle. The special series allows for the handling of pallets of any size thanks to the great variety of frames. The new 3.000 Kg model offers a load capacity of 3.000 Kilograms thanks to its reinforced structure.

### GS PREMIUM \*

The GS premium pallet truck offers innovative cutting-edge solutions, such as the tilt guide wheel, the load lowering speed control, the covered steering wheel, apart from a certified hydraulic unit for 50.000 Cycles.

### GS SILENCE \*

The GS Silenced hand pallet truck has been designed to strongly reduce the noise emission even in the worse working condition: rough and tiled surfaces. The result is an ideal machine for the usage on residential areas, deliveries and in supermarket stores.

GS series is a suitable practical solution meeting all the needs of manual handling.

For the transport of fragile and delicate loads, such as loads of glass or ceramics, the premium version includes a sensitive and safe forks lowering control system.

The special series, with its broad choice of forks dimensions, guarantees solutions to handle any type of pallet; finally, the pro version, also available with a 3.000 Kg load capacity, completes the range of Lifter pallet trucks that are completely made in Italy.

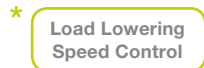
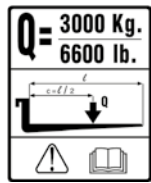

Available accessories: tandem rollers, polyurethane rollers (as a standard on Premium), rubber guide wheels, manual control brake



**MAXIMUM PRESSURE VALVE**  
When the maximum load capacity is exceeded, oil pressure exceeds its maximum limit and the valve automatically locks the forks. Thus possible structural damage is avoided.



**PAINTING**  
Following an appropriate conditioning operation the frame is varnished with epoxy-polyester powder at a temperature of 250° to guarantee maximum resistance to wear and atmospheric agents.

# Manual Trucks

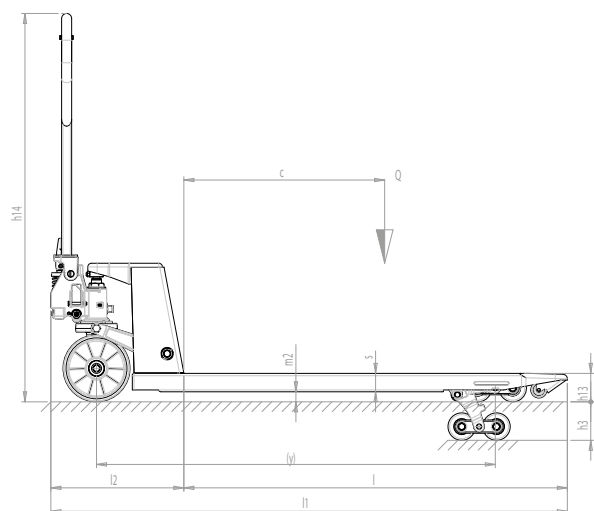
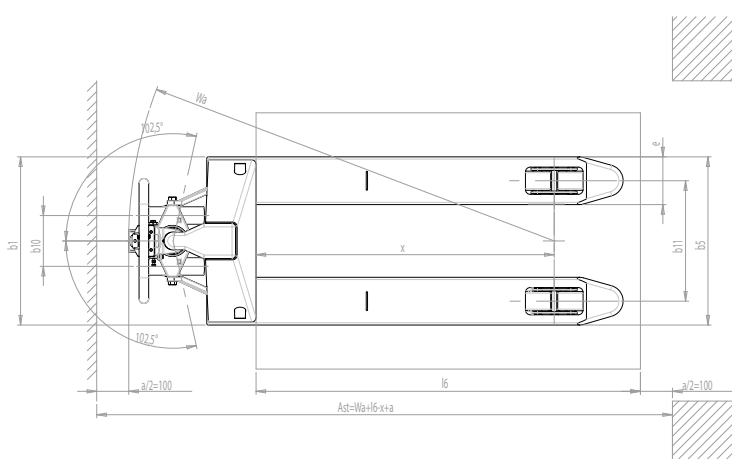

## DESCRIPTION

1.2 MODEL	GS BASIC 22 S2-S4	GS PRO 25 S2-S4	GS PREMIUM 25 S2-S4	GS/AV PRO 25 S2-S4	GS PRO 30 S4	GS/L PRO 25 S2-S4	GS/M PRO 25 S2-S4	GS B 20 S4
1.3 DRIVE	MANUAL	MANUAL	MANUAL	MANUAL	MANUAL	MANUAL	MANUAL	MANUAL
1.4 OPERATOR TYPE	PEDESTRIAN	PEDESTRIAN	PEDESTRIAN	PEDESTRIAN	PEDESTRIAN	PEDESTRIAN	PEDESTRIAN	PEDESTRIAN
1.5 LOAD CAPACITY	Q kg	2200	2500	2500	2500	3000	2500	2000
1.6 LOAD CENTRE DISTANCE	c mm	600	600	600	600	600	400	600
1.8 LOAD DISTANCE, CENTRE OF DRIVE AXLE TO FORK	x mm	932	932	932	932	932	582	945
1.9 WHEEL BASE	y mm	1192	1192	1192	1192	1192	842	1192

## WEIGHTS

2.1 SERVICE WEIGHT	kg	61-63	61-63	63-65	61-63	79	66-68	52-54	71
2.2 AXLE LOAD LADEN, FRONT/REAR	kg	655/1606-1608	767/1794-1796	739/1824-1826	738/1823-1825	889/2190	771/1795-1797	691/1861-1863	693/1378
2.3 AXLE LOAD UNLADEN, FRONT/REAR	kg	42/19-21	42/19-21	43/20-22	42/19-21	53/26	46/20-22	35/17-19	48/23

## TYRES/CHASSIS

3.1 TYRES		P/N	P/N	P/P	P/N	P/N	P/N	P/N	P/A
3.2 TYRE SIZE, FRONT (Ø x width)		200x45	200x55	200x55	200x55	200x55	200x55	200x55	200x55
3.3 TYRE SIZE, REAR (Ø x width)		82x82-60	82x82-60	82x82-60	82x82-60	82x60	82x82-60	82x82-60	50x58
3.4 SIDE WHEELS (Ø x width)		-	-	-	-	-	-	-	-
3.5 WHEELS, NUMBER (x=DRIVEN) FRONT/REAR		2/2-2/4	2/2-2/4	2/2-2/4	2/2-2/4	2/4	2/2-2/4	2/2-2/4	2/4
3.6 TREAD, FRONT	b10 mm	155	155	155	155	155	155	155	130
3.7 TREAD, REAR	b11 mm	375	375	375	375	375	535	250	365

## DIMENSIONS

4.4 LIFT	h3 mm	115	115	115	115	115	115	115	115
4.9 HEIGHT OF TILLER IN DRIVE POSITION MIN/MAX	h14 mm	690/1160	690/1160	690/1160	415/1250	690/1160	690/1160	690/1160	690/1160
4.15 HEIGHT, LOWERED	h13 mm	85	85	85	85	85	85	85	55
4.19 OVERALL LENGTH	l1 mm	1550	1550	1550	1550	1550	1550	1200	1550
4.20 LENGTH TO FACE OF FORKS	l2 mm	400	400	400	400	400	400	400	400
4.21 OVERALL WIDTH	b1 mm	525	525	525	525	525	685	400	525
4.22 FORK DIMENSIONS	s/e/l mm	55/150/1150	55/150/1150	55/150/1150	55/150/1150	55/150/1150	55/150/1150	55/150/800	40/160/1150
4.25 DISTANCE BETWEEN FORK ARMS	b5 mm	525	525	525	525	525	685	400	525
4.32 GROUND CLEARANCE, CENTRE OF WHEEL BASE	m2 mm	30	30	30	30	30	30	30	15
4.34 AISLE WIDTH FOR PALLETS 800x1200 LENGTHWISE	Ast mm	1835	1835	1835	1835	1835	1835	1435	1822
4.35 TURNING RADIUS	Wa mm	1367	1367	1367	1367	1367	1367	1017	1367

## PERFORMANCE DATA

5.2 LIFT SPEED, LADEN/UNLADEN	strokes	13/13	13/13	13/13	13/6	13/13	13/13	13/13	13/13
-------------------------------	---------	-------	-------	-------	------	-------	-------	-------	-------

G = Rubber, N = Nylon, P = Polyurethane, A = Steel, NE = Nylon extra

FORK LENGTH	l	mm	600	800	950	1000	1150	1220	1350	1500	1800	2000
LOAD CENTRE DISTANCE	c	mm	300	400	475	500	600	610	675	750	900	1000
WHEELS, NUMBER (x=DRIVEN) FRONT/REAR			2/2-2/4	2/2-2/4	2/2-2/4	2/2-2/4	2/2-2/4	2/2-2/4	2/4	2/4	2/4	2/4
OVERALL LENGTH	l1	mm	1000	1200	1350	1400	1550	1620	1750	1900	2200	2400
LOAD DISTANCE, CENTRE OF DRIVE AXLE TO FORK	x	mm	382	582	732	782	932	1002	1132	1282	1582	1782
WHEEL BASE	y	mm	642	842	992	1042	1192	1262	1392	1542	1842	2042
SERVICE WEIGHT	kg		52-54	57-59	59-61	60-62	63-65	65-67	90	112	127	134
AXLE LOAD LADEN, FRONT/REAR	kg		356/2196-2198	580/1017-1435	688/1871-1873	716/1844-1846	739/1824-1826	821/1744-1746	880/1710	929/1717	1002/1625	1037/1597
AXLE LOAD UNLADEN, FRONT/REAR	kg		37/15-17	40/17-19	40/19-21	39/21-23	43/20-22	44/21-23	59/31	66/46	76/51	80/54
TURNING RADIUS	Wa	mm	817	1017	1167	1217	1367	1437	1567	1717	2017	2217
AISLE WIDTH FOR PALLETS 800x1200-l LENGTHWISE	Ast	mm	1235	1435	1585	1635	1835	1855	1985	2135	2435	2635

# Mr. Hydro

## GS/G

The galvanised pallet truck offers good resistance to corrosion thanks to the hot dip galvanizing process of the frame, the control linkages of the pump body and the handle.

## GS/X

In this version the parts getting in contact with the load and the operator are of AISI 304 electropolished stainless steel, while the remaining parts are subject to a hot dip galvanising treatment.

## GS/I

Inox aisi 304 electropolished stainless steel is used for all metal sheet parts, while the pump is made of brass.

GS/Galvanised,  
Stainless steel and Galvinox

Load Lowering  
Speed Control



### HYDRAULIC PUMP MADE OF BRASS

In the stainless steel version the hydraulic pump is made of brass to offer maximum resistance to humidity and oxidation.



### ELECTROPOLISHING

The use of Inox AISI 304, combined with an electropolishing surface treatment, provides the machine with better appearance. Resistance to corrosion also guarantees maximum hygiene.

# Manual Trucks

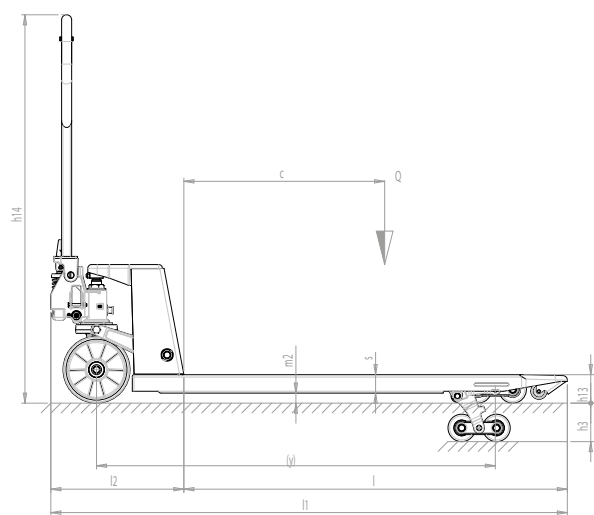
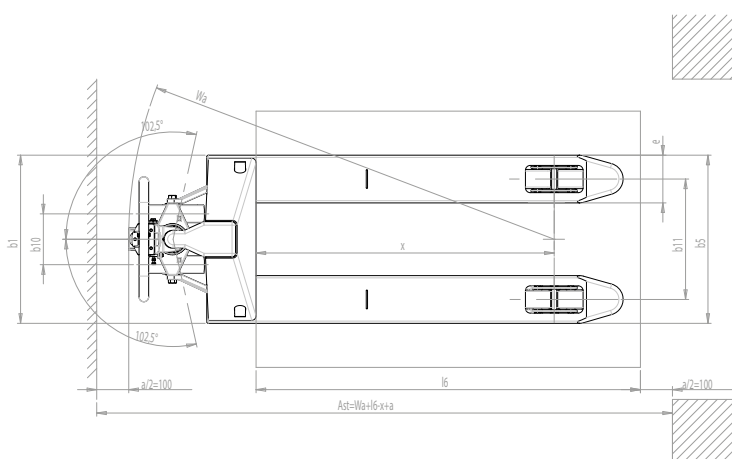

DESCRIPTION							
1.2	MODEL		GS/G 25 S2-S4	GS/X 25 S2-S4	GS/I 25 S2-S4	GS/L G 25 S2-S4	GS/M G 25 S2-S4
1.3	DRIVE		MANUAL	MANUAL	MANUAL	MANUAL	MANUAL
1.4	OPERATOR TYPE		PEDESTRIAN	PEDESTRIAN	PEDESTRIAN	PEDESTRIAN	PEDESTRIAN
1.5	LOAD CAPACITY	Q	kg	2500	2500	2500	2500
1.6	LOAD CENTRE DISTANCE	c	mm	600	600	600	400
1.8	LOAD DISTANCE, CENTRE OF DRIVE AXLE TO FORK	x	mm	932	932	932	582
1.9	WHEEL BASE	y	mm	1192	1192	1192	842
WEIGHTS							
2.1	SERVICE WEIGHT		kg	61-63	62-64	67-69	66-68
2.2	AXLE LOAD LADEN, FRONT/REAR		kg	738/1823-1823	739/1823-1825	742/1825-1827	771/1795-1797
2.3	AXLE LOAD UNLADEN, FRONT/REAR		kg	42/19-21	43/19-21	46/21-23	46/20-22
35	35						
TYRES/CHASSIS							
3.1	TYRES			N/N	NE/NE	NE/NE	N/N
3.2	TYRE SIZE, FRONT (Ø x width)			200x50	200x50	200x50	200x50
3.3	TYRE SIZE, REAR (Ø x width)			82x82-60	82x82-60	82x82-60	82x82-60
3.4	SIDE WHEELS (Ø x width)			-	-	-	-
3.5	WHEELS, NUMBER (x=DRIVEN) FRONT/REAR			2/2-2/4	2/2-2/4	2/2-2/4	2/2-2/4
3.6	TREAD, FRONT	b10	mm	155	155	155	155
3.7	TREAD, REAR	b11	mm	375	375	375	250
DIMENSIONS							
4.4	LIFT	h3	mm	115	115	115	115
4.9	HEIGHT OF TILLER IN DRIVE POSITION MIN/MAX	h14	mm	690/1160	690/1160	690/1160	690/1160
4.15	HEIGHT, LOWERED	h13	mm	85	85	85	85
4.19	OVERALL LENGTH	l1	mm	1550	1550	1550	1200
4.20	LENGTH TO FACE OF FORKS	l2	mm	400	400	400	400
4.21	OVERALL WIDTH	b1	mm	525	525	525	685
4.22	FORK DIMENSIONS	s/e/l	mm	55/150/1150	55/150/1150	55/150/1150	55/150/800
4.25	DISTANCE BETWEEN FORK ARMS	b5	mm	525	525	525	400
4.32	GROUND CLEARANCE, CENTRE OF WHEEL BASE	m2	mm	30	30	30	30
4.35	TURNING RADIUS	Wa	mm	1367	1367	1367	1017
PERFORMANCE DATA							
5.2	LIFT SPEED, LADEN/UNLADEN		strokes	13/13	13/13	13/13	13/13
COMPONENT SPECIFICATIONS							
	HYDRAULIC UNIT			GALVANIZED	GALVANIZED	BRASS	GALVANIZED
	FRAME			GALVANIZED	INOX	INOX	GALVANIZED
	PUSH RODS			GALVANIZED	GALVANIZED	INOX	GALVANIZED
	ROCKER ARM			GALVANIZED	GALVANIZED	INOX	GALVANIZED
	WHEELS			NYLON	NYLON EXTRA	NYLON EXTRA	NYLON
	LOAD ROLLERS			NYLON	NYLON EXTRA	NYLON EXTRA	NYLON
	TILLER			GALVANIZED	INOX	INOX	GALVANIZED

G = Rubber, N = Nylon, P = Polyurethane, A = Steel, NE = Nylon extra

FORK LENGTH	l	mm	800	1150	1220
LOAD CENTRE DISTANCE	c	mm	400	600	610
WHEELS, NUMBER (x=DRIVEN) FRONT/REAR			2/2-2/4	2/2-4/2	2/2-2/4
OVERALL LENGTH	l1	mm	1200	1550	1620
LOAD DISTANCE, CENTRE OF DRIVE AXLE TO FORK	x	mm	582	932	1002
WHEEL BASE	y	mm	842	1192	1262
SERVICE WEIGHT		kg	55-57	61-63	63-65
AXLE LOAD LADEN, FRONT/REAR		kg	579/1976-1978	738/1823-1825	820/1743-1745
AXLE LOAD UNLADEN, FRONT/REAR		kg	39/16-18	42/19-21	43/20-22
TURNING RADIUS	Wa	mm	1017	1367	1437
AISLE WIDTH FOR PALLETS 800x1200-1 LENGTHWISE	Ast	mm	1435	1835	1855

# GS/P25

PX20

The Lifter scale truck series is available in two models, both of which equipped with an intelligent weighing device with many operating options. It is suitable for lifting and carrying heavy loads; it is therefore very precise and functional in all internal weighing operations.



#### DISPLAY

The PX20 pallet truck is a simple, economic and robust tool to be used for the weighing of transported loads. Its large-sized LCD display allows for easy reading of weight and the setting of tare simply and immediately.



#### GS/P25 - STAINLESS STEEL

GS/P differs from PX20 due to its hydraulic unit of higher load capacity (2.500 kg) and the bigger number of functions, such as the items counter and the load totalization indicator. The pallet truck may also be equipped with a thermal printer, memory card SD or may be provided in the INOX version.



#### FRAME STRUCTURE

The structure is made up of a double frame and a lower fork on which a counter fork is placed; both forks house four load cells that allow for a uniform load distribution, thus keeping weighing precision even in case of collision and unbalanced load.



#### MEMORY CARD SD

GS/P pallet truck is available with printing on SD memory card and approved weighing.

# Scales Trucks

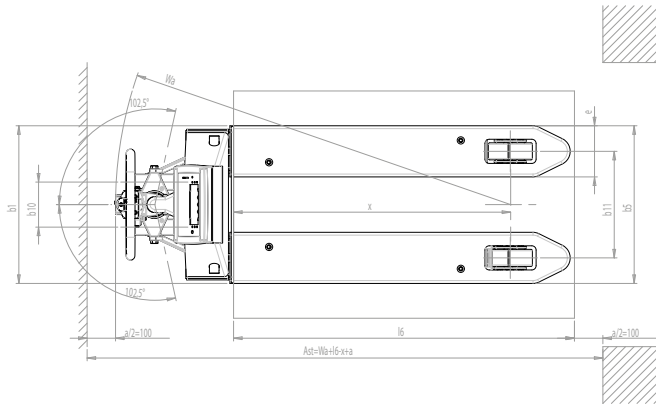
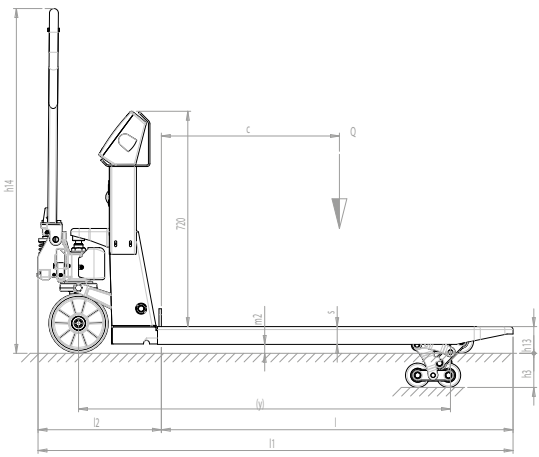

GS/P

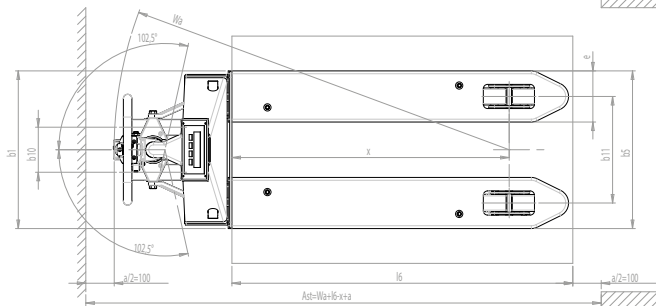
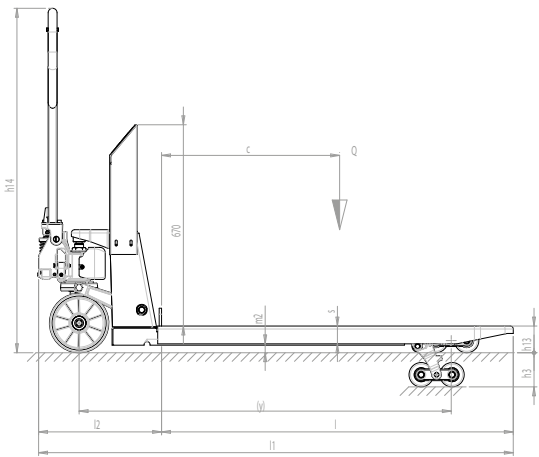

PX20

## DESCRIPTION

1.2 MODEL		GS/P	GS/P CE-M HOMOLOGATION	GS/P INOX	PX20
1.3 DRIVE		MANUAL	MANUAL	MANUAL	MANUAL
1.4 OPERATOR TYPE		PEDESTRIAN	PEDESTRIAN	PEDESTRIAN	PEDESTRIAN
1.5 LOAD CAPACITY	Q kg	2500	2500	2500	2000
1.6 LOAD CENTRE DISTANCE	c mm	600	600	600	600
1.8 LOAD DISTANCE, CENTRE OF DRIVE AXLE TO FORK	x mm	975,5	975,5	975,5	975
1.9 WHEEL BASE	y mm	1250	1250	1250	1255

## WEIGHTS

2.1 SERVICE WEIGHT	kg	124	124	132	113
2.2 AXLE LOAD LADED, FRONT/REAR	kg	787/1837	787/1837	790/1842	633/1480
2.3 AXLE LOAD UNLADEN, FRONT/REAR	kg	77/47	77/47	82/50	71/42

## TYRES/CHASSIS

3.1 TYRES		P/P	P/P	NE/NE	P/P
3.2 TYRE SIZE, FRONT (Ø x width)		200x55	200x55	200x50	200x55
3.3 TYRE SIZE, REAR (Ø x width)		82x60	82x60	82x60	82x60
3.4 SIDE WHEELS (Ø x width)		-	-	-	-
3.5 WHEELS, NUMBER (x=DRIVEN) FRONT/REAR		2/4	2/4	2/4	2/4
3.6 TREAD, FRONT	b10 mm	155	155	155	155
3.7 TREAD, REAR	b11 mm	375	375	375	375

## DIMENSIONS

4.4 LIFT	h3 mm	115	115	115	115
4.9 HEIGHT OF TILLER IN DRIVE POSITION MIN/MAX	h14 mm	690/1160	690/1160	690/1160	690/1160
4.15 HEIGHT, LOWERED	h13 mm	90	90	90	90
4.19 OVERALL LENGTH	l1 mm	1596	1596	1596	1596
4.20 LENGHT TO FACE OF FORKS	l2 mm	411	411	411	411
4.21 OVERALL WIDTH	b1 mm	555	555	555	555
4.22 FORK DIMENSIONS	s/e/l mm	60/180/1185	60/180/1185	60/180/1185	60/180/1185
4.25 DISTANCE BETWEEN FORK ARMS	b5 mm	555	555	555	555
4.32 GROUND CLEARANCE, CENTRE OF WHEEL BASE	m2 mm	30	30	30	30
4.34 AISLE WIDTH FOR PALLETS 800x1200 LENGHTWISE	Ast mm	1851	1851	1851	1815
4.35 TURNING RADIUS	Wa mm	1426	1426	1426	1390

## PERFORMANCE DATA

5.2 LIFT SPEED, LADEN/UNLADEN	strokes	13/13	13/13	13/13	13/13
-------------------------------	---------	-------	-------	-------	-------

## SCALE

6.4 BATTERY VOLTAGE, NOMINAL CAPACITY	V/Ah	6/4	6/4	6/4	6/1,1
DISPLAY		Liquid crystals/6 digits 25mm	Liquid crystals/6 digits 25mm	Liquid crystals/6 digits 25mm	Liquid crystals/6 digits 25mm
UNITS OF MEASUREMENT		kg/lb	kg/lb	kg/lb	kg/lb
FUNCTIONS		Tare/Auto-off/Weight totalizer/Piece counting	Tare/Auto-off/Weight totalizer/Piece counting	Tare/Auto-off/Weight totalizer/Piece counting	Tare/Unbalanced load/Auto-off
AUTONOMY	h	50	50	50	30
PRECISION	% full scale	0,05	0,05	0,05	0,05
LOAD CELLS	n.	4	4	4	4
DIVISION	kg	0,5	1	0,5	0,5

# HX

## HX10M - HX10E

The HX10 series, available in manual and electric version, makes possible an easy and light lifting to a height of 800 mm, thus becoming a practical work platform, which is suitable for places such as machine workshops. This pallet truck is also able to carry out the support function and material supply along the assembly and production lines.



Load Lowering  
Speed Control

Battery and external battery charger  
Also available in GEL version  
and with an integrated battery charger



### FRONT AND REAR STABILIZERS

The new control linkage makes the entry onto the closed side of the pallet possible by slight lifting, facilitating successive handling phases. Furthermore, a certain machine stability has been obtained using load rollers in a more advanced position and providing front stabilizers as standard equipment. Rear stabilizers, in turn, render work stable and safe even in the case of elevated loads once the 400 mm of lifting up have been exceeded.



### CONTROL LEVER

The hydraulic unit has been recently redesigned to allow for less effort at the steering wheel for all loads and a quick elevated function (30 cycles) for loads up to 150 kg.



### AUTO LEVELLING SYSTEM

- Automatic system whose photocell adjusts the height of the forks, maintaining the work height set.
- An optical and acoustic signal is activated at every fork movement.
- Possibility of adjusting the photocell both in height and reading angle.
- Micro-limit switch, active both on the way up to prevent superfluous absorption of energy and on the way down to protect the operator.



### EMERGENCY PUSHBUTTON

The emergency pushbutton with a battery cut-off (isolator) switch function allows for a safer work.



# High Lift Pallet Trucks

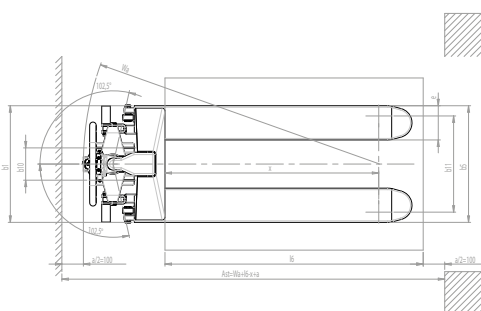
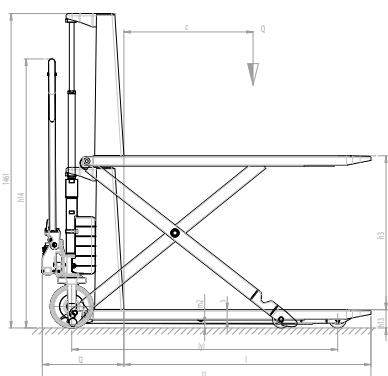

HX10M

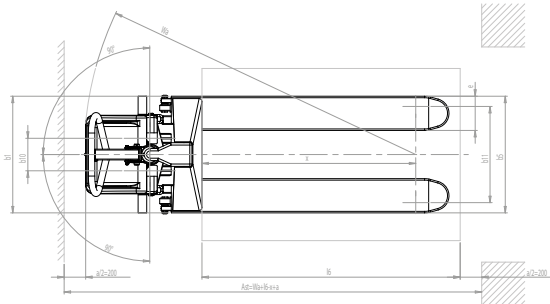
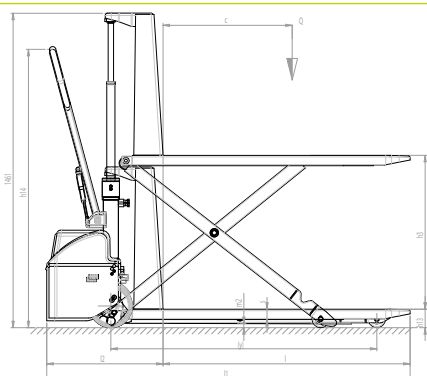

HX10E

## DESCRIPTION

1.2 MODEL		HX10M 1150x540	HX10M 1150x680	HX10E 1150x540	HX10E 1150x680	HX10E 1500x540	HX10E 1800x540	HX10E 2000x540
1.3 DRIVE		MANUAL	MANUAL	MANUAL	MANUAL	MANUAL	MANUAL	MANUAL
1.4 OPERATOR TYPE		PEDESTRIAN	PEDESTRIAN	PEDESTRIAN	PEDESTRIAN	PEDESTRIAN	PEDESTRIAN	PEDESTRIAN
1.5 LOAD CAPACITY	Q kg	1000	1000	1000	1000	1000	1000	1000
1.6 LOAD CENTRE DISTANCE	c mm	600	600	600	600	762	900	1000
1.8 LOAD DISTANCE, CENTRE OF DRIVE AXLE TO FORK	x mm	993	993	993	993	1368	1643	1843
1.9 WHEEL BASE	y mm	1236	1236	1236	1236	1611	1886	2086

## WEIGHTS

2.1 SERVICE WEIGHT	kg	104	111	139 (144*)	146	235 (240*)	259 (264*)	262 (267*)
2.2 AXLE LOAD LADEN, FRONT/REAR	kg	339/765	344/767	429/710 (434/710*)	434/712 (439/712*)	531/704 (536/704*)	572/687 (577/687*)	584/678 (589/678*)
2.3 AXLE LOAD UNLADEN, FRONT/REAR	kg	79/25	84/27	111/28 (116/28*)	116/30	155/80 (160/80*)	178/81 (183/81*)	180/82 (185/82*)

## TYRES/CHASSIS

3.1 TYRES		P/P	P/P	G/P	G/P	G/P	G/P	G/P
3.2 TYRE SIZE, FRONT (Ø x width)		200x45	200x45	200x50	200x50	200x50	200x50	200x50
3.3 TYRE SIZE, REAR (Ø x width)		80x50	80x50	80x50	80x50	80x50	80x50	80x50
3.4 SIDE WHEELS (Ø x width)		-	-	-	-	-	-	-
3.5 WHEELS, NUMBER (x=DRIVEN) FRONT/REAR		2/2	2/2	2/2	2/2	2/2	2/2	2/2
3.6 TREAD, FRONT	b10 mm	150	150	150	150	150	150	150
3.7 TREAD, REAR	b11 mm	447	587	447	587	447	447	447

## DIMENSIONS

4.4 LIFT	h3 mm	715	715	715	715	715	715	715
4.9 HEIGHT OF TILLER IN DRIVE POSITION MIN/MAX	h14 mm	415/1250	415/1250	915/1300	915/1300	915/1300	915/1300	915/1300
4.15 HEIGHT, LOWERED	h13 mm	85	85	85	85	85	85	85
4.19 OVERALL LENGTH	l1 mm	1526	1526	1690	1690	2065	2340	2540
4.20 LENGTH TO FACE OF FORKS	l2 mm	376	376	540	540	540	540	540
4.21 OVERALL WIDTH	b1 mm	540	680	540	680	540	540	540
4.22 FORK DIMENSIONS	s/e/l mm	48/160/1150	48/160/1150	48/160/1150	48/160/1150	48/160/1525	48/160/1800	48/160/2000
4.25 DISTANCE BETWEEN FORK ARMS	b5 mm	540	680	540	680	540	540	540
4.32 GROUND CLEARANCE, CENTRE OF WHEEL BASE	m2 mm	21	21	21	21	21	21	21
4.34 AISLE WIDTH FOR PALLETS 800x1200 LENGTHWISE	Ast mm	1779	1779	1948	1948	2273	2548	2748
4.35 TURNING RADIUS	Wa mm	1372	1372	1541	1541	1916	2191	2391

## PERFORMANCE DATA

5.2 LIFT SPEED, LADEN/UNLADEN	strokes	62/30	62/30	0,08/0,13	0,08/0,13	0,08/0,13	0,08/0,13	0,08/0,13
5.3 LOWERING SPEED, LADEN/UNLADEN	m/s	0	0	0,13/0,06	0,13/0,06	0,13/0,06	0,13/0,06	0,13/0,06

## ELECTRIC MOTORS

6.2 LIFT MOTOR POWER	kW			1,6	1,6	1,6	1,6	1,6
6.4 BATTERY VOLTAGE, NOMINAL CAPACITY C20	V/Ah			12/60	12/60	12/60	12/60	12/60
6.5 BATTERY WEIGHT	kg			14	14	14	14	14

8.4 SOUND LEVEL AT DRIVER'S EAR	dB(A)			67	67	67	67	67
---------------------------------	-------	--	--	----	----	----	----	----

\*G=Rubber, N=Nylon, P=Polyurethane, A=Steel, NE=Nylon extra \* On board battery charger version

MODEL		HX10E 1150x540 GEL/PLUS	HX10E 1500x540 GEL/PLUS	HX10E 1800x540 GEL/PLUS	HX10E 2000x540 GEL/PLUS
SERVICE WEIGHT	kg	145	241	265	268
AXLE LOAD LADEN, FRONT/REAR	kg	435/710	537/704	578/687	590/678
AXLE LOAD UNLADEN, FRONT/REAR	kg	116/28	161/80	184/81	186/82
OVERALL LENGTH	l1 mm	1720	2095	2370	2570
LENGTH TO FACE OF FORKS	l2 mm	570	570	570	570
AISLE WIDTH FOR PALLETS 800x1200 LENGTHWISE	Ast mm	1978	2303	2578	2778
TURNING RADIUS	Wa mm	1571	1946	2221	2421
BATTERY VOLTAGE, NOMINAL CAPACITY C5	V/Ah	12/50 GEL; 60 PLUS	12/50 GEL; 60 PLUS	12/50 GEL; 60 PLUS	12/50 GEL; 60 PLUS
BATTERY WEIGHT	kg	19	19	19	19



 **Lifter**  
BY PRADAC

**CX12**



## ELECTRIC PALLET TRUCKS

---

The electric pallet trucks range has been designed to obtain compact machines able to operate even in spaces of extremely limited dimensions, where small sizes of trucks are a prerequisite.

Range of products allows to cover several applications, from light to heavy duty use. On the whole series it is possible to do modifications in order to meet customer needs. The AC technology or the double lifting system are some of the mechanical and technological devices selected to improve and develop solutions that meet material handling market requests.

# CX

12 - 14

The CX electric pallet trucks are available in different versions. They are suitable for carrying loads on smooth or paved surfaces. Its small size and turning radius make it the ideal tool to work with in confined spaces, such as lorries or narrow aisles.



Integrated battery and battery charger



### STEERING WHEEL AND CONTROLS

- Ergonomic tiller
- Luminous indicator for battery state control.
- Butterfly valves for traction control.
- Safety pushbutton with warning buzzer.
- Forks way up/down control positioned on both sides of the handle (only on CX14).
- Hour counter in the Plus and Gel versions (only on CX14).
- "Tortoise" pushbutton for slow motion, which allows for the carrying out of operations with the tiller in vertical position.



### PLUS BATTERIES

The Plus versions are equipped with semitraction batteries that guarantee greater autonomy and an operative life that allows for up to 5 times higher a number of charge life cycles. Thanks to the design of its guard, access to batteries is easy and rapid; this model also optimally combines size, power and low running cost also due to the integrated batteries and battery charger.

### COMPACT DIMENSIONS

Thanks to the B1 width, which is equal to the fork gauge, and the L2 measurement of 360 mm, the CX12 electronic pallet truck is the ideal tool for the handling of pallets on lorries, in supermarket aisles and any application where space is limited. This machine is the best configuration in its category thanks to the frame width, in-service weight and turning radius, guaranteeing great maneuverability and compactness.



### STABILIZERS

Two stabilizing wheels enable movement even on more difficult surfaces thus guaranteeing maximum stability in any condition of use.

# Electric Pallet Trucks

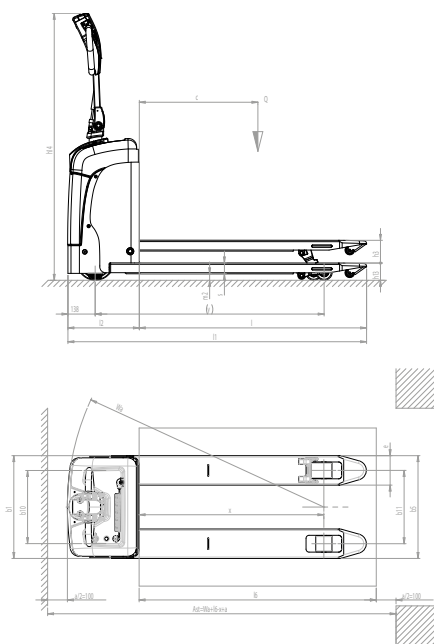

CX12

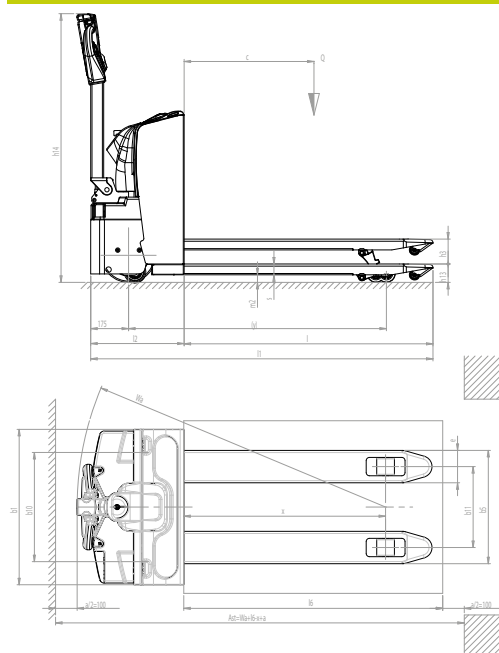

CX14

DESCRIPTION									
1.2	MODEL		CX12 S2-S4	CX12 PLUS S2-S4	CX12 GEL S2-S4	CX14 S2-S4	CX14 PLUS S2-S4	CX14 GEL S2-S4	
1.3	DRIVE		ELECTRIC	ELECTRIC	ELECTRIC	ELECTRIC	ELECTRIC	ELECTRIC	
1.4	OPERATOR TYPE		PEDESTRIAN	PEDESTRIAN	PEDESTRIAN	PEDESTRIAN	PEDESTRIAN	PEDESTRIAN	
1.5	LOAD CAPACITY	Q	kg	1200	1200	1200	1400	1400	
1.6	LOAD CENTRE DISTANCE	c	mm	600	600	600	600	600	
1.8	LOAD DISTANCE, CENTRE OF DRIVE AXLE TO FORK	x	mm	886	886	886	935	935	
1.9	WHEEL BASE	y	mm	1119	1119	1119	1192	1192	
WEIGHTS									
2.1	SERVICE WEIGHT WITH BATTERY (see line 6,5)		kg	155-157	165-167	160-162	201-207	246-250	248-252
2.2	AXLE LOAD LADEN, FRONT/REAR		kg	431/924-926	441/924-926	436/924-926	562/1041-1045	599/1047-1051	600/1048-1052
2.3	AXLE LOAD UNLADEN, FRONT/REAR		kg	124/31-33	134/31-33	129/31-33	170/33-37	207/39-43	208/40-44
TYRES/CHASSIS									
3.1	TYRES			G+P/P	G+P/P	G+P/P	G+P/P	G+P/P	
3.2	TYRE SIZE, FRONT (Ø x width)			186x50	186x50	186x50	250x76	250x76	250x76
3.3	TYRE SIZE, REAR (Ø x width)			82x82-60	82x82-60	82x82-60	82x80-60	82x80-60	82x80-60
3.4	SIDE WHEELS (Ø x width)			75x25	75x25	75x25	100x40	100x40	100x40
3.5	WHEELS, NUMBER (x=DRIVEN) FRONT/REAR			1x+2/2-2/4	1x+2/2-2/4	1x+2/2-2/4	1x+2/2-2/4	1x+2/2-2/4	1x+2/2-2/4
3.6	TREAD, FRONT	b10	mm	369	369	369	506	506	
3.7	TREAD, REAR	b11	mm	371	371	371	375	375	
DIMENSIONS									
4.4	LIFT	h3	mm	115	115	115	115	115	
4.9	HEIGHT OF TILLER IN DRIVE POSITION MIN/MAX	h14	mm	885/1345	885/1345	885/1345	786/1242	786/1242	786/1242
4.15	HEIGHT, LOWERED	h13	mm	85	85	85	85	85	
4.19	OVERALL LENGTH	l1	mm	1510	1510	1510	1650	1650	
4.20	LENGTH TO FACE OF FORKS	l2	mm	360	360	360	500	500	
4.21	OVERALL WIDTH	b1	mm	520	520	520	720	720	
4.22	FORK DIMENSIONS	s/e/l	mm	55/150/1150	55/150/1150	55/150/1150	50/150/1150	50/150/1150	50/150/1150
4.25	DISTANCE BETWEEN FORK ARMS	b5	mm	520	520	520	525	525	
4.32	GROUND CLEARANCE, CENTRE OF WHEEL BASE	m2	mm	30	30	30	35	35	
4.34	AISLE WIDTH FOR PALLETS 800x1200 LENGTHWISE	Ast	mm	1782	1782	1782	1900	1900	
4.35	TURNING RADIUS	Wa	mm	1268	1268	1268	1435	1435	
PERFORMANCE DATA									
5.1	TRAVEL SPEED, LADEN/UNLADEN		km/h	4,3/4,8	4,3/4,8	4,3/4,8	4,5/4,7	4,5/4,7	4,5/4,7
5.2	LIFT SPEED, LADEN/UNLADEN		m/s	0,03/0,04	0,03/0,04	0,03/0,04	0,02/0,03	0,02/0,03	0,02/0,03
5.3	LOWERING SPEED, LADEN/UNLADEN		m/s	0,05/0,02	0,05/0,02	0,05/0,02	0,04	0,04	0,04
5.8	MAX GRADEABILITY, LADEN/UNLADEN			10/25	10/25	10/25	5/10	5/10	5/10
5.10	SERVICE BRAKE			ELECTRIC	ELECTRIC	ELECTRIC	ELECTRIC	ELECTRIC	
ELECTRIC MOTORS									
6.1	DRIVE MOTOR POWER		kW	0,35	0,35	0,35	0,7	0,7	0,7
6.2	LIFT MOTOR POWER		kW	0,4	0,4	0,4	0,4	0,4	0,4
6.4	BATTERY VOLTAGE, NOMINAL CAPACITY C20		V/Ah	24/60	24/60 (45 C5)	24/48 (40 C5)	24/70 (C20)	24/118 (C5)	24/105 (C5)
6.5	BATTERY WEIGHT		kg	28	38	32	32	78	80
8.4	SOUND LEVEL AT DRIVER'S EAR		dB(A)	67	67	67	76	76	76

G = Rubber, N = Nylon, P = Polyurethane, A = Steel, NE = Nylon extra

MODEL	CX12 S2-S4	CX12 S2-S4	CX14 S2-S4		
FORK LENGTH	l	mm	800	1000	1000
LOAD CENTRE DISTANCE	c	mm	400	500	500
WHEELS, NUMBER (x=DRIVEN) FRONT/REAR			1x+2/2-2/4	1x+2/2-2/4	1x+2/2-2/4
OVERALL LENGTH	l1	mm	1160	1360	1500
WHEEL BASE	y	mm	769	969	1042
LOAD DISTANCE, CENTRE OF DRIVE AXLE TO FORK	x	mm	536	736	785
SERVICE WEIGHT WITH BATTERY (see line 6,5)		kg	150-152	153-155	199-203
AXLE LOAD LADEN, FRONT/REAR		kg	333/1017-1019	415/938-940	561/1038-1042
AXLE LOAD UNLADEN, FRONT/REAR		kg	121/29-31	123/30-32	169/30-34
TURNING RADIUS	Wa	mm	918	1118	1285
AISLE WIDTH FOR PALLETS 800x1200 LENGTHWISE	Ast	mm	1382	1582	1700

# QX

18 - 20 - 20DL

## QX/DL

In this version the QX20 structure still has a load capacity of 2.000 Kg but has been extended with the addition of a central cylinder that allows for the lifting of an 800 kg load on the plated forks in order to create a smooth support platform for the operator. The load backrest also guarantees total safety. The plated forks and clamps can be lifted independently through the pushbuttons on the wheelhouse.

The QX pallet truck series meets the needs of a vast number of applications guaranteeing high performance, even during the haviest operations. The AC technology introduced in the traction motor promotes high energy efficiency and a longer battery charging duration; the absence of brushes in the motor and the simpler structure of the motor increase system reliability. Furthermore, the double lifting version keeps the high functionality of the electrical pallet truck and combines it with the practical convenience of stackers.



### TILLER

- Ergonomic tiller
- Luminous indicator for battery state control.
- Butterfly valves for traction control.
- Safety pushbutton with warning buzzer.
- Forks way up/down control positioned on both sides of the handle
- Hour counter
- "Tortoise" pushbutton for slow motion, which allows for the carrying out of operations with the tiller in vertical position.
- Ideal for running in confined spaces.



### MOTOR WHEEL AND STABILIZING WHEELS

The motor wheel equipped with AC technology guarantees an excellent speed control system, with or without load on board (6 km/h). Two stabilizing wheels also enable movement even on more difficult surfaces, ensuring maximum stability in any condition of use.



### FORKS AND CONNECTION

The structure of QX pallet trucks is designed to guarantee maximum solidity and reliability: front forks are made of very thick cast iron just like clevis and other connecting rod parts. Impact on pallets and difficult surfaces is no longer a problem!



### AC TECHNOLOGY

AC technology guarantees more energy efficiency and longer battery charging duration, thus reducing maintenance cost. Furthermore the absence of brushes in the motor and the simpler motor structure increase system reliability.

# Electric Pallet Trucks

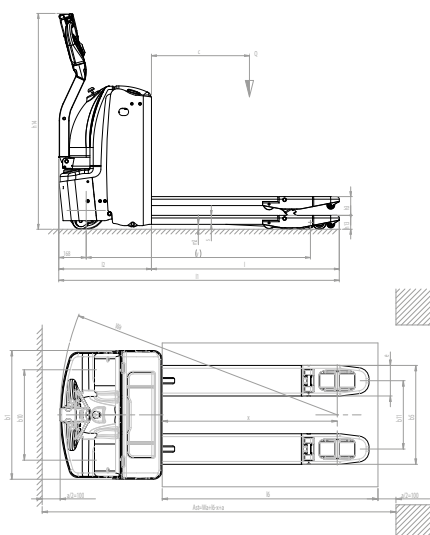

**QX18-20**

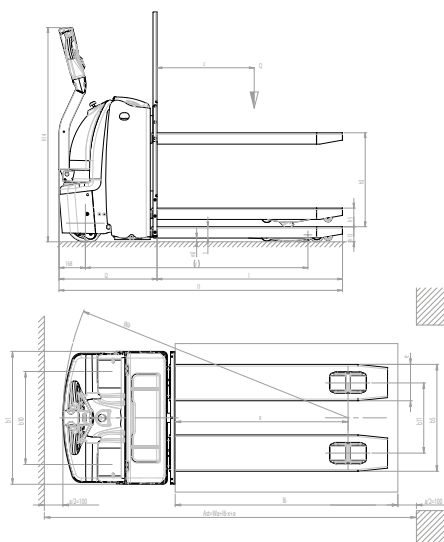

**QX20DL**

DESCRIPTION					
1.2	MODEL		QX18 S2-S4	QX20 S2-S4	QX20 DL S4
1.3	DRIVE		ELECTRIC	ELECTRIC	ELECTRIC
1.4	OPERATOR TYPE		PEDESTRIAN	PEDESTRIAN	PEDESTRIAN
1.5	LOAD CAPACITY	Q	kg	1800	2000
1.6	LOAD CENTRE DISTANCE	c	mm	600	600
1.8	LOAD DISTANCE, CENTRE OF DRIVE AXLE TO FORK	x	mm	973	973
1.9	WHEEL BASE	y	mm	1373	1373
WEIGHTS					
2.1	SERVICE WEIGHT WITH BATTERY (see line 6,5)		kg	510-515	615
2.2	AXLE LOAD LADEN, FRONT/REAR		kg	874/1436-1441	980-1635
2.3	AXLE LOAD UNLADEN, FRONT/REAR		kg	388/122-127	440-175
TYRES/CHASSIS					
3.1	TYRES			P+P/P	P+P/P
3.2	TYRE SIZE, FRONT (Ø x width)			230x75	230x75
3.3	TYRE SIZE, REAR (Ø x width)			85x90-80	85x80
3.4	SIDE WHEELS (Ø x width)			100x40	100x40
3.5	WHEELS, NUMBER (x=DRIVEN) FRONT/REAR			1x+2/2-2/4	1x+2/4
3.6	TREAD, FRONT	b10	mm	506	506
3.7	TREAD, REAR	b11	mm	380	380
DIMENSIONS					
4.4	LIFT	h3	mm	115	580
4.6	INITIAL LIFT	h5	mm	-	115
4.9	HEIGHT OF TILLER IN DRIVE POSITION MIN/MAX	h14	mm	784/1320	784/1320
4.15	HEIGHT, LOWERED	h13	mm	85	93
4.19	OVERALL LENGTH	l1	mm	1715	1755
4.20	LENGTH TO FACE OF FORKS	l2	mm	565	605
4.21	OVERALL WIDTH	b1	mm	716	716
4.22	FORK DIMENSIONS	s/e/l	mm	55/170/1150	70/196/1150
4.25	DISTANCE BETWEEN FORK ARMS	b5	mm	550	576
4.32	GROUND CLEARANCE, CENTRE OF WHEEL BASE	m2	mm	30	23
4.34	aisle width for pallets 800x1200 lengthwise	Ast	mm	2002	2079
4.35	TURNING RADIUS	Wa	mm	1575	1575
PERFORMANCE DATA					
5.1	TRAVEL SPEED, LADEN/UNLADEN		km/h	6,0/6,0	6,0/6,0
5.2	LIFT SPEED, LADEN/UNLADEN		m/s	0,04/0,05	0,04/0,05
5.3	LOWERING SPEED, LADEN/UNLADEN		m/s	0,05/0,04	0,05/0,04
5.8	MAX GRADEABILITY, LADEN/UNLADEN			10/20	10/20
5.10	SERVICE BRAKE			ELECTRIC	ELECTRIC
ELECTRIC MOTORS					
6.1	DRIVE MOTOR POWER		kW	1,2	1,5
6.2	LIFT MOTOR POWER		kW	1,2	1,2
6.4	BATTERY VOLTAGE, NOMINAL CAPACITY C5		V/Ah	24/180	24/200
6.5	BATTERY WEIGHT		kg	190	188
8.4	SOUND LEVEL AT DRIVER'S EAR		dB(A)	58,4	58,4

G = Rubber, N = Nylon, P = Polyurethane, A = Steel, NE = Nylon extra

MODEL	QX18 S2-S4		QX20 S2-S4	
FORK LENGTH	l	mm	1000	1000
LOAD CENTRE DISTANCE	c	mm	500	500
OVERALL LENGTH	l1	mm	1565	1565
WHEEL BASE	y	mm	1223	1223
LOAD DISTANCE, CENTRE OF DRIVE AXLE TO FORK	x	mm	823	823
SERVICE WEIGHT WITH BATTERY (see line 6,5)		kg	502-507	502-507
AXLE LOAD LADEN, FRONT/REAR		kg	868/1434-1439	922/1580-1585
AXLE LOAD UNLADEN, FRONT/REAR		kg	382/120-125	382/120-125
TURNING RADIUS	Wa	mm	1425	1425
aisle width for pallets 800x1200 lengthwise	Ast	mm	1802	1802
BATTERY				
BATTERY VOLTAGE, NOMINAL CAPACITY C5		V/Ah	24/180	24/230
BATTERY WEIGHT		kg	185	212

# QX

20P – 22

## QX22

The QX22 is ideal to move loads rapidly and over long distances. Structural solidity, quality of components, elevated load capacity (2.2 T), excellent shift speed (10 km/h) and battery capacity (315 ah) make QX22 the best choice for those who work on different shifts.

QX models equipped with a footplate are highly versatile electrical pallet trucks which, thanks to their folding footplate, can be used in confined spaces or over medium distances with an excellent shift speed (8 - 10 km/h). The strong frame, the AC traction motor technology and the braking system with energy recovery are just few samples of the high technology of this machine.



### WHEELS

- Wheel drive of considerable power (2 kW) and big size (Ø mm 230x75).
- Two stabilizing wheels enable movement even on more difficult surfaces, ensuring maximum stability in any condition of use.



### REPLACEMENT OF BATTERIES QX22

- The battery compartment is equipped with a removable side frame and an internal roller that minimizes effort during the battery extraction and connection phases. A trolley is also available upon request to replace the battery rapidly.



### TECHNOLOGY AND SAFETY

- The machine is equipped with 3 sensors that automatically adjust speed control and reduce it up to 6 km/h when at least one of the following events occurs:
1. Lateral protection guards are not raised and are not rought to the "run" position.
  2. The turning radius sensor registers a curve with an angle over 8 degrees.
  3. The footplate is kept in closed position.



### MOTORS

- Lifting (1.2 kW) and traction (2 kW) motors have both a voltage of 24 Volt. The vertical assembly not only allows for a more rapid access to all the parts but also minimizes room cluttering-up and wiring stress.



# Electric Pallet Trucks

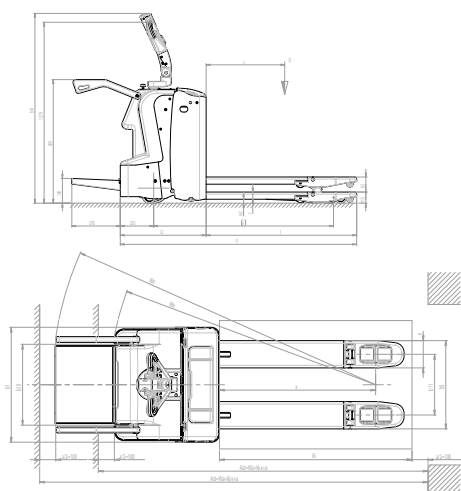

**QX20P**

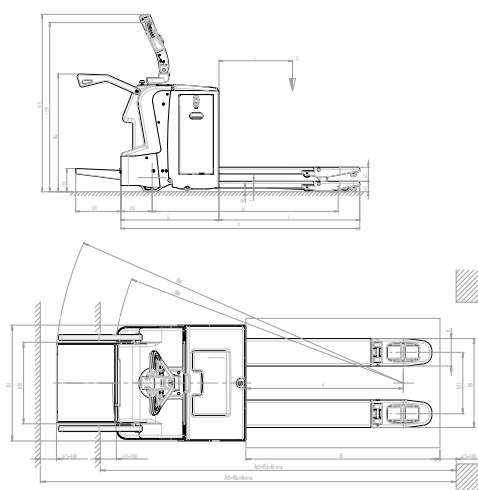

**QX22**

## DESCRIPTION

1.2	MODEL	QX20P S2-S4	QX22 S2-S4
1.3	DRIVE	ELECTRIC	ELECTRIC
1.4	OPERATOR TYPE	PEDESTRIAN/STANDING	PEDESTRIAN/STANDING
1.5	LOAD CAPACITY	Q kg	2200
1.6	LOAD CENTRE DISTANCE	c mm	600
1.8	LOAD DISTANCE, CENTRE OF DRIVE AXLE TO FORK	x mm	973
1.9	WHEEL BASE	y mm	1373

## WEIGHTS

2.1	SERVICE WEIGHT WITH BATTERY (see line 6,5)	kg	559-564	632-637
2.2	AXLE LOAD LADEN, FRONT/REAR	kg	1582-1587/977	1872-1877/960
2.3	AXLE LOAD UNLADEN, FRONT/REAR	kg	117-122/442	190-195/442

## TYRES/CHASSIS

3.1	TYRES		P/P+P	P/P+P
3.2	TYRE SIZE, FRONT (Ø x width)		85x90-80	85x90-80
3.3	TYRE SIZE, REAR (Ø x width)		230x75	230x75
3.4	SIDE WHEELS (Ø x width)		100x40	100x40
3.5	WHEELS, NUMBER (x=DRIVEN) FRONT/REAR		2/4 - 1x+2	2/4 - 1x+2
3.6	TREAD, FRONT	b10 mm	380	380
3.7	TREAD, REAR	b11 mm	506	506

## DIMENSIONS

4.4	LIFT	h3 mm	115	115
4.9	HEIGHT OF TILLER IN DRIVE POSITION MIN/MAX	h14 mm	1107/1450	1107/1450
4.15	HEIGHT, LOWERED	h13 mm	85	85
4.19	OVERALL LENGTH (PLATFORM CLOSED/OPEN)	l1 mm	1806/2176	1950/2320
4.20	LENGTH TO FACE OF FORKS (PLATFORM CLOSED/OPEN)	l2 mm	656/1026	800/1170
4.21	OVERALL WIDTH	b1 mm	716	716
4.22	FORK DIMENSIONS	s/e/l mm	55/170/1150	55/170/1150
4.25	DISTANCE BETWEEN FORK ARMS	b5 mm	550	550
4.32	GROUND CLEARANCE, CENTRE OF WHEEL BASE	m2 mm	30	30
4.34	AISLE WIDTH FOR PALLETS 800x1200 LENGTHWISE (PLATFORM CLOSED/OPEN)	Ast mm	2317/2675	2458/2815
4.35	TURNING RADIUS (PLATFORM CLOSED/OPEN)	Wa mm	1657/2015	1798/2155

## PERFORMANCE DATA

5.1	TRAVEL SPEED, LADEN/UNLADEN (PLATFORM CLOSED/OPEN)	km/h	6,0/6,0 (8,0/8,0)	6,0/6,0 (10,0/10,0)
5.2	LIFT SPEED, LADEN/UNLADEN	m/s	0,04/0,05	0,04/0,05
5.3	LOWERING SPEED, LADEN/UNLADEN	m/s	0,05/0,04	0,05/0,04
5.8	MAX GRADEABILITY, LADEN/UNLADEN		8/20	8/20
5.10	SERVICE BRAKE		ELECTRIC	ELECTRIC

## ELECTRIC MOTORS

6.1	DRIVE MOTOR POWER	kW	2	2
6.2	LIFT MOTOR POWER	kW	1,2	1,2
6.4	BATTERY VOLTAGE, NOMINAL CAPACITY C5	V/Ah	24/180	24/230
6.5	BATTERY WEIGHT	kg	190	216

8.4	SOUND LEVEL AT DRIVER'S EAR	dB(A)	56,4	56,4
-----	-----------------------------	-------	------	------

G = Rubber, N = Nylon, P = Polyurethane, A = Steel, NE = Nylon extra

MODEL		QX20P S2-S4	QX22 S2-S4
FORK LENGTH	l mm	1000	1000
LOAD CENTRE DISTANCE	c mm	500	500
OVERALL LENGTH (PLATFORM CLOSED/OPEN)	l1 mm	1656/2026	1800/2170
WHEEL BASE	y mm	1223	1370
LOAD DISTANCE, CENTRE OF DRIVE AXLE TO FORK	x mm	823	823
SERVICE WEIGHT WITH BATTERY (see line 6,5)	kg	551-556	624-629
AXLE LOAD LADEN, FRONT/REAR	kg	1581-1586/970	1869-1874/955
AXLE LOAD UNLADEN, FRONT/REAR	kg	116-121/435	187-192/437
TURNING RADIUS (PLATFORM CLOSED/OPEN)	Wa mm	1507/1865	1648/2005
AISLE WIDTH FOR PALLETS 800x1200 LENGTHWISE (PLATFORM CLOSED/OPEN)	Ast mm	1884/2242	2025/2382

## BATTERY QX20P

BATTERY VOLTAGE, NOMINAL CAPACITY C5	V/Ah	24/180	24/230
BATTERY WEIGHT	kg	185	218

## BATTERY QX22

BATTERY VOLTAGE, NOMINAL CAPACITY C5	V/Ah	24/230	24/315
BATTERY WEIGHT	kg	218	280



Walcor

Walcor

Walcor

Walcor

Walcor

Walcor

Lifter  
BY PRADAC

RX 10

Lifter  
BY PRADAC



## STACKERS

---

The stackers line offers a wide range of solutions, from manual and semi-electric to electric machines. Products are designed to work in narrow spaces and cover different type of uses, from the light to heavy duty. Moreover stackers can be modified offering tailor made solutions on the base of customers individual needs.

# MX

## Manual Stackers

MX Series is not only an excellent compromise between price and performance but also a very resistant machine. Reinforced forks, steel pulley and forks precisely driven by rollers, are some of the main features of this stacker. The machine is also equipped with a foot pedal to lift forks, which considerably reduces the operator's effort.



### STEEL PULLEY

A big chain and a strong steel pulley ensure great resistance and reliability even working with the max load capacity.



### FOOT BRAKE

The foot brake performs the parking brake function.



### TILLER

The plastic cover increases the ergonomic character of the MX handle, rendering the raising and transport operations even "lighter".

The 3-position control lever (down, neutral, up) is placed on the steering wheel to foster manoeuvrability.



### MAX PRESSURE VALVE

When maximum load capacity is exceeded, the oil pressure exceeds its maximum limit and the valve automatically stops the forks from lifting. In this way, possible structural damage is avoided.

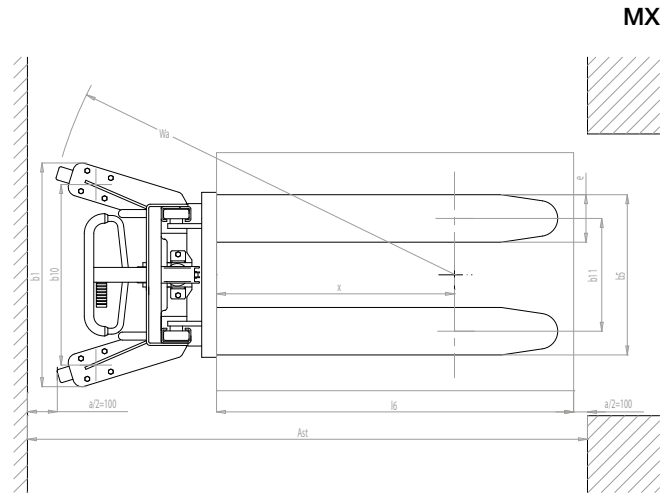
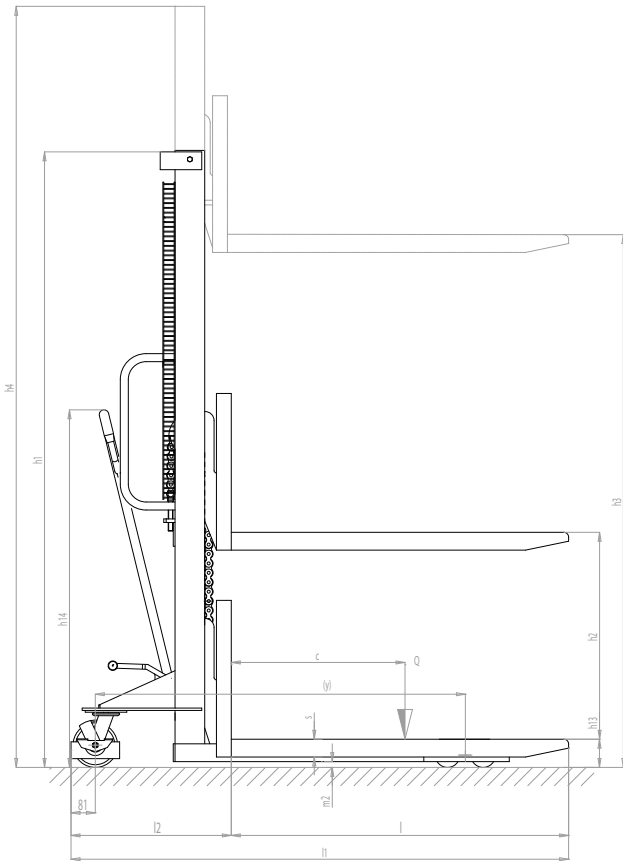

MX

## DESCRIPTION

1.2	MODEL		MX 510	MX 516	MX 1016
1.3	DRIVE		MANUAL	MANUAL	MANUAL
1.4	OPERATOR TYPE		PEDESTRIAN	PEDESTRIAN	PEDESTRIAN
1.5	LOAD CAPACITY	Q kg	500	500	1000
1.6	LOAD CENTRE DISTANCE	c mm	600	600	600
1.8	LOAD DISTANCE, CENTRE OF DRIVE AXLE TO FORK	x mm	800	800	800
1.9	WHEEL BASE	y mm	1240	1240	1240

## WEIGHTS

2.1	SERVICE WEIGHT WITH BATTERY	kg	185	200	210
2.2	AXLE LOAD LADEN, FRONT/REAR	kg	202/483	213/487	309/901
2.3	AXLE LOAD UNLADEN, FRONT/REAR	kg	113/72	123/77	129/81

## TYRES/CHASSIS

3.1	TYRES		N/N	N/N	N/N
3.2	TYRE SIZE, FRONT (Ø x width)		150x40	150x40	150x40
3.3	TYRE SIZE, REAR (Ø x width)		80x70	80x70	80x70
3.5	WHEELS, NUMBER (x=DRIVEN) FRONT/REAR		2/2	2/2	2/2
3.6	TREAD, FRONT	b10 mm	600	600	600
3.7	TREAD, REAR	b11 mm	380	380	380

## DIMENSIONS

4.2	HEIGHT, MAST LOWERED	h1 mm	1490	2080	2080
4.3	FREE LIFT	h2 mm	910	1510	1510
4.4	LIFT	h3 mm	910	1510	1510
4.5	HEIGHT, MAST EXTENDED	h4 mm	1490	2080	2080
4.9	HEIGHT OF TILLER IN DRIVE POSITION MIN/MAX	h14 mm	490/1090	490/1090	490/1090
4.15	HEIGHT, LOWERED	h13 mm	90	90	90
4.19	OVERALL LENGTH	l1 mm	1690	1690	1690
4.20	LENGTH TO FACE OF FORKS	l2 mm	540	540	540
4.21	OVERALL WIDTH	b1/b2 mm	740	740	740
4.22	FORK DIMENSIONS	s/e/l mm	60/170/1150	60/170/1150	60/170/1150
4.24	FORK-CARRIAGE WIDTH	b3 mm	550	550	550
4.25	DISTANCE BETWEEN FORK ARMS	b5 mm	550	550	550
4.32	GROUND CLEARANCE, CENTRE OF WHEEL BASE	m2 mm	30	30	30
4.34	AISLE WIDTH FOR PALLETS 800x1200 LENGTHWISE	Ast mm	2166	2166	2166
4.35	TURNING RADIUS	Wa mm	1400	1400	1400

## PERFORMANCE DATA

5.2	LIFT SPEED, LADEN/UNLADEN	m/s	37/37	73/73	73/73
5.3	LOWERING SPEED, LADEN/UNLADEN	m/s	0.16/0.05	0.16/0.05	0.12/0.03
5.10	SERVICE BRAKE		-	-	-

## ELECTRIC MOTORS

6.2	LIFT MOTOR POWER	kW	-	-	-
6.4	BATTERY VOLTAGE, NOMINAL CAPACITY C5	V/Ah	-	-	-
6.5	BATTERY WEIGHT	kg	-	-	-
8.4	SOUND LEVEL AT DRIVER'S EAR	dB(A)	-	-	-

G = Rubber, N = Nylon, P = Polyurethane, A = Steel, NE = Nylon extra

# TX

The TX Series are characterized by manual traction and electrohydraulic lifting technology. Version 12 (1.2 t) includes polyurethane wheels as standard to reduce resistance and effort required even with full load capacity.

### TX/STRADDLE

The main feature of the straddle series, which is available for the TX models, gives the possibility to adjust forks and clamps for great versatility in the handling of loads of different sizes.



Integrated battery and battery charges



#### START KEY AND BATTERY CUT-OFF (ISOLATOR) SWITCH

The start key on the TX stacker performs a double function:

- It switches the stacker on/off
- is an emergency control, i.e. it completely stops battery power supply and thus prevents the lifting of forks.



#### FOOT BRAKE

The foot brake performs the parking brake function.



#### ADJUSTABLE BUFFERS

The TX 12 is equipped with adjustable buffers that minimize possible oscillation during lifting.

# Semi-Electric Stackers

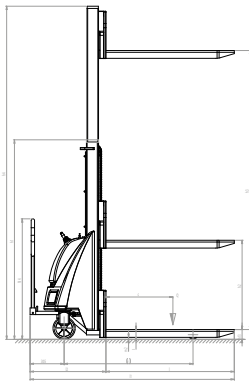

TX

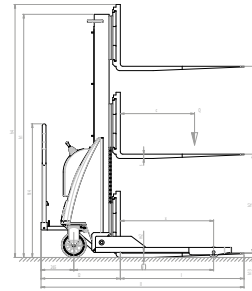

TX STRADDLE

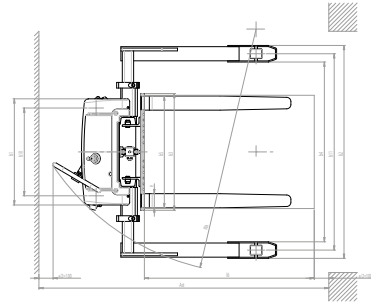
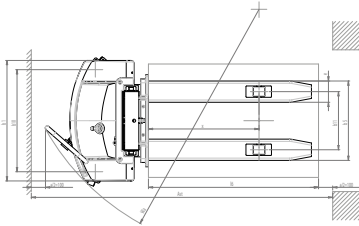

DESCRIPTION						
1.2	MODEL		TX 10/20	TX 12/35	TX 10/16 STRADDLE	
1.3	DRIVE		MANUAL	MANUAL	MANUAL	
1.4	OPERATOR TYPE		PEDESTRIAN	PEDESTRIAN	PEDESTRIAN	
1.5	LOAD CAPACITY	Q	kg	1000	1200	1000
1.6	LOAD CENTRE DISTANCE	c	mm	600	600	600
1.8	LOAD DISTANCE, CENTRE OF DRIVE AXLE TO FORK	x	mm	630	780	755
1.9	WHEEL BASE	y	mm	965	1155	1130
WEIGHTS						
2.1	SERVICE WEIGHT WITH BATTERY		kg	321	474	415
2.2	AXLE LOAD LADEN, FRONT/REAR		kg	253/1068	537/1137	453/962
2.3	AXLE LOAD UNLADEN, FRONT/REAR		kg	222/99	345/129	270/145
TYRES/CHASSIS						
3.1	TYRES			G/N	P/N	G/N
3.2	TYRE SIZE, FRONT (Ø x width)			200x50	200x50	200x50
3.3	TYRE SIZE, REAR (Ø x width)			82x70	82x70	82x70
3.5	WHEELS, NUMBER (x=DRIVEN) FRONT/REAR			2/2	2/2	2/2
3.6	TREAD, FRONT	b10	mm	620	720	620
3.7	TREAD, REAR	b11	mm	410	410	1080/1387
DIMENSIONS						
4.2	HEIGHT, MAST LOWERED	h1	mm	2370	2250	1970
4.3	FREE LIFT	h2	mm	1910	80	1510
4.4	LIFT	h3	mm	1910	3410	1510
4.5	HEIGHT, MAST EXTENDED	h4	mm	2370	3915	2045
4.9	HEIGHT OF TILLER IN DRIVE POSITION MIN/MAX	h14	mm	60/1080	60/1080	60/1080
4.15	HEIGHT, LOWERED	h13	mm	90	90	35
4.19	OVERALL LENGTH	l1	mm	1750	1850	1640
4.20	LENGTH TO FACE OF FORKS	l2	mm	600	700	640
4.21	OVERALL WIDTH	b1/b2	mm	750	850	750/1199-1504
4.22	FORK DIMENSIONS	s/e/l	mm	70/150/1150	70/150/1150	35/100/1000
4.24	FORK-CARRIAGE WIDTH	b3	mm	650	650	825
4.25	DISTANCE BETWEEN FORK ARMS	b5	mm	560	560	230/790
4.26	DISTANCE BETWEEN LEGS MIN/MAX	b4	mm	-	-	965/1270
4.32	GROUND CLEARANCE, CENTRE OF WHEEL BASE	m2	mm	20	20	40
4.34	aisle WIDTH FOR PALLETS 800x1200 LENGTHWISE	Ast	mm	2336	2540	2588
4.35	TURNING RADIUS	Wa	mm	1440	1760	1790
PERFORMANCE DATA						
5.2	LIFT SPEED, LADEN/UNLADEN		m/s	0,09/0,12	0,09/0,12	0,09/0,12
5.3	LOWERING SPEED, LADEN/UNLADEN		m/s	0,4/0,1	0,4/0,1	0,4/0,1
5.10	SERVICE BRAKE			-	-	MANUAL
ELECTRIC MOTORS						
6.2	LIFT MOTOR POWER		kW	1,6	2,2	1,6
6.4	BATTERY VOLTAGE, NOMINAL CAPACITY C5		V/Ah	12/70 (C20)	24/70 (C20)	12/70 (C20)
6.5	BATTERY WEIGHT		kg	16	32	32
8.4	SOUND LEVEL AT DRIVER'S EAR		dB(A)	67	67	67

G = Rubber, N = Nylon, P = Polyurethane, A = Steel, NE = Nylon extra

MODEL			TX 10/09	TX 10/16	TX 12/25	TX 12/29
LIFT	h3	mm	810	1510	2410	2810
HEIGHT, MAST LOWERED	h1	mm	1300	1970	1780	1980
FREE LIFT	h2	mm	810	1510	-	-
HEIGHT, MAST EXTENDED	h4	mm	1300	1970	2985	3385
SERVICE WEIGHT WITH BATTERY (SEE ROW 6.5)		kg	296	311	415	431
AXLE LOAD LADEN, FRONT/REAR		kg	228/1068	241/1070	493/1122	502/1129
AXLE LOAD UNLADEN, FRONT/REAR		kg	197/99	210/101	301/114	310/121

# RX

RX is the most compact in the stackers' range, single mast, completely electric, suitable for loads up to 1.000 kg and elevation up to 1.600 mm, allowing a comfortable, safe use, with low maintenance costs, thanks to robust design with easy access for maintenance. RX combines compactness and ergonomics, offering a wide range of applications distribution and manufacturing environments and it is not intended for continuous daily activity.



**EASY MAINTENANCE**  
Strong ABS carter/cover with storage compartments on top, easily removable to speed up maintenance operations. The bottom access opening allows an immediate disassembly of motor wheel, portal and tiller without lifting the machine.



**ERGONOMICS**  
Ergonomic tiller placed laterally to increase visibility, ensuring an optimal arrangement of components inside the motor compartment. RX 10/16 solves perfectly the problem of handling goods in narrow spaces and corridors



**VERSATILITY**  
It's ideal to move, even horizontally, palletized goods and at the same time it can be used as an adjustable worktable, reducing stress for the operator who must place goods on a shelf. Forks thickness 60 mm for an easier entrance inside pallet, while working in elevation.



**BATTERY PACK**  
Starting batteries (light-traction PLUS or GEL type as option), lightweight and inexpensive, allow up to 3 hours autonomy.



# Electric Stackers

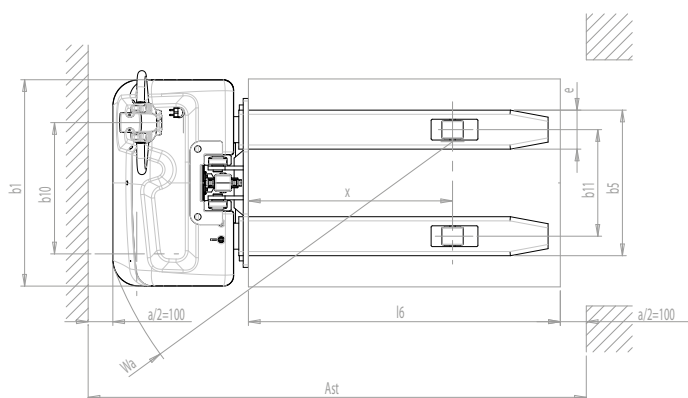
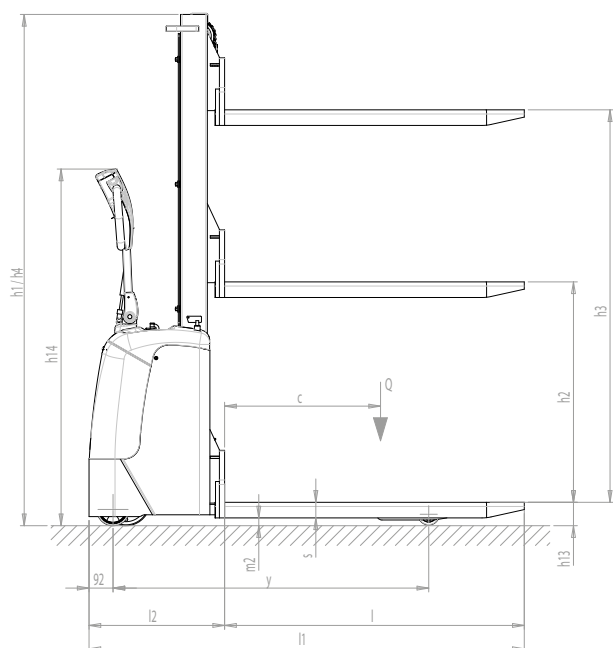

## DESCRIPTION

		RX 10/09	RX 10/09 "PLUS"	RX 10/09 "GEL"	RX 10/16	RX 10/16 "PLUS"	RX 10/16 "GEL"
1.2	MODEL						
1.3	DRIVE	ELECTRIC	ELECTRIC	ELECTRIC	ELECTRIC	ELECTRIC	ELECTRIC
1.4	OPERATOR TYPE	PEDESTRIAN	PEDESTRIAN	PEDESTRIAN	PEDESTRIAN	PEDESTRIAN	PEDESTRIAN
1.5	LOAD CAPACITY	Q kg	1000	1000	1000	1000	1000
1.6	LOAD CENTRE DISTANCE	c mm	600	600	600	600	600
1.8	LOAD DISTANCE, CENTRE OF DRIVE AXLE TO FORK	x mm	786	786	786	786	786
1.9	WHEEL BASE	y mm	1165	1165	1165	1165	1165

## WEIGHTS

2.1	SERVICE WEIGHT WITH BATTERY (SEE ROW 6.5)	kg	337	345	345	363	371	371
2.2	AXLE LOAD LADEN, FRONT/REAR	kg	405/932	411/934	411/934	426/937	434/937	434/937
2.3	AXLE LOAD UNLADEN, FRONT/REAR	kg	240/97	246/99	246/99	261/102	269/102	269/102

## TYRES/CHASSIS

3.1	TYRES		G+P/P	G+P/P	G+P/P	G+P/P	G+P/P	G+P/P
3.2	TYRE SIZE, FRONT (Ø x width)		186x50	186x50	186x50	186x50	186x50	186x50
3.3	TYRE SIZE, REAR (Ø x width)		82x70	82x70	82x70	82x70	82x70	82x70
3.4	SIDE WHEELS (Ø x width)		125x45	125x45	125x45	125x45	125x45	125x45
3.5	WHEELS, NUMBER (x=DRIVEN) FRONT/REAR		1x+1/2	1x+1/2	1x+1/2	1x+1/2	1x+1/2	1x+1/2
3.6	TREAD, FRONT	b10 mm	505	505	505	505	505	505
3.7	TREAD, REAR	b11 mm	410	410	410	410	410	410

## DIMENSIONS

4.2	HEIGHT, MAST LOWERED	h1 mm	1270	1270	1270	1970	1970	1970
4.3	FREE LIFT	h2 mm	810	810	810	1510	1510	1510
4.4	LIFT	h3 mm	810	810	810	1510	1510	1510
4.5	HEIGHT, MAST EXTENDED	h4 mm	1270	1270	1270	1970	1970	1970
4.9	HEIGHT OF TILLER IN DRIVE POSITION MIN/MAX	h14 mm	930/1365	930/1365	930/1365	930/1365	930/1365	930/1365
4.15	HEIGHT, LOWERED	h13 mm	90	90	90	90	90	90
4.19	OVERALL LENGTH	l1 mm	1675	1675	1675	1675	1675	1675
4.20	LENGTH TO FACE OF FORKS	l2 mm	522	522	522	522	522	522
4.21	OVERALL WIDTH	b1 mm	794	794	794	794	794	794
4.22	FORK DIMENSIONS	s/e/l mm	60/150/1153	60/150/1153	60/150/1153	60/150/1153	60/150/1153	60/150/1153
4.24	FORK-CARRIAGE WIDTH	b3 mm	650	650	650	650	650	650
4.25	DISTANCE BETWEEN FORK ARMS	b5 mm	560	560	560	560	560	560
4.32	GROUND CLEARANCE, CENTRE OF WHEEL BASE	m2 mm	20	20	20	20	20	20
4.34	AISLE WIDTH FOR PALLETS 800x1200 LENGTHWISE	Ast mm	2120	2120	2120	2120	2120	2120
4.35	TURNING RADIUS	Wa mm	1344	1344	1344	1344	1344	1344

## PERFORMANCE DATA

5.1	TRAVEL SPEED, LADEN/UNLADEN	km/h	3,7/4,3	3,7/4,3	3,7/4,3	3,7/4,3	3,7/4,3	3,7/4,3
5.2	LIFT SPEED, LADEN/UNLADEN	m/s	0,11/0,18	0,11/0,18	0,11/0,18	0,11/0,18	0,11/0,18	0,11/0,18
5.3	LOWERING SPEED, LADEN/UNLADEN	m/s	0,18/0,18	0,18/0,18	0,18/0,18	0,18/0,18	0,18/0,18	0,18/0,18
5.8	MAX GRADEABILITY, LADEN/UNLADEN	%	9/25	9/25	9/25	9/25	9/25	9/25
5.10	SERVICE BRAKE		ELECTRIC	ELECTRIC	ELECTRIC	ELECTRIC	ELECTRIC	ELECTRIC

## ELECTRIC MOTORS

6.1	DRIVE MOTOR POWER	kW	0,35	0,35	0,35	0,35	0,35	0,35
6.2	LIFT MOTOR POWER	kW	2,2	2,2	2,2	2,2	2,2	2,2
6.4	BATTERY VOLTAGE, NOMINAL CAPACITY C5	V/Ah	24/70 (C20)	24/54	24/50	24/70 (C20)	24/54	24/50
6.5	BATTERY WEIGHT	kg	30	38	38	30	38	38

8.4	SOUND LEVEL AT DRIVER'S EAR	dB(A)	63	63	63	63	63	63
-----	-----------------------------	-------	----	----	----	----	----	----

G = Rubber, N = Nylon, P = Polyurethane, A = Steel, NE = Nylon extra

# GX

This compact sized stacker, powerful and reliable, is the ideal solution to work in confined spaces. The Duplex mast allows a lifting capacity from 2500 up to 3500 mm with a FreeLift version available. The reduced width (800 mm), the lateral driving system and the wide mast positioning assure great manoeuvrability, stability and visibility. The built in battery and charger with integrated cable and plug make the GX Series a plug and play unit.

## GX Basic

The BASIC version is equipped with a starting type battery, a tiller made with metal tube and ergonomic controls. This configuration is the best value for money choice.



## GX Evo

The EVO version is equipped with more powerful batteries - semitraction type - that allow longer endurance and greater number of charging cycles. The ergonomic tiller made with PLASTIC offers a comfortable grip. A specific electronic board controls the fork movement offering a smooth start-stop.



## GX Freelift

The GX EVO is also available with a total free lift configuration, permitting to rise the forks up to 1.492 mm from the ground level, without increasing the minimum machine height (1.965 mm). For this reason the truck can also be used in working spaces with reduced height.



### FINGERTIP CONTROLS

Fully integrated tiller system with throttle, fork control safety pushbutton, horn, and turtle button. Hourmeter, battery status indicator and a higher ergonomics are the standard equipment of the EVO version.



### MANOEUVRABILITY

Having the same size as the EuroPallet (800 mm), the overall width of the GX allows the unit to work in narrow spaces and corridors, with increased manoeuvrability and a reduced turning radius. The combination of the lateral drive, the wide mast and the low cover offer an outstanding visibility.



### COVER

Strong ABS cover with storage compartments on top, easily removable to speed up maintenance operations. The bottom access opening allows an immediate disassembly of motor wheel, portal and tiller without lifting the machine. A Schuko plug with spiral cable is available for an easy battery charging.



### BATTERY PACK

The separate battery compartment is the housing of starting batteries on BASIC version, SEMI-TRACTION on the EVO one. Such batteries are lightweight and inexpensive and allow up to a 3 hours working autonomy. GEL version available.

# Electric Stackers

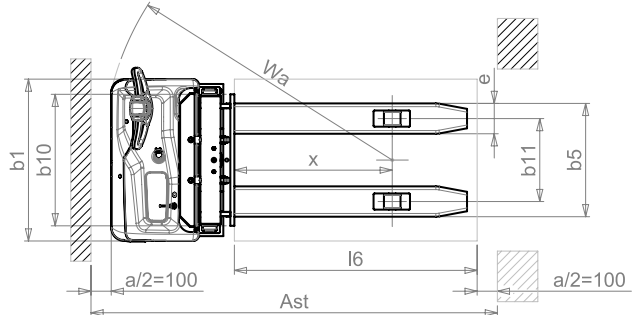
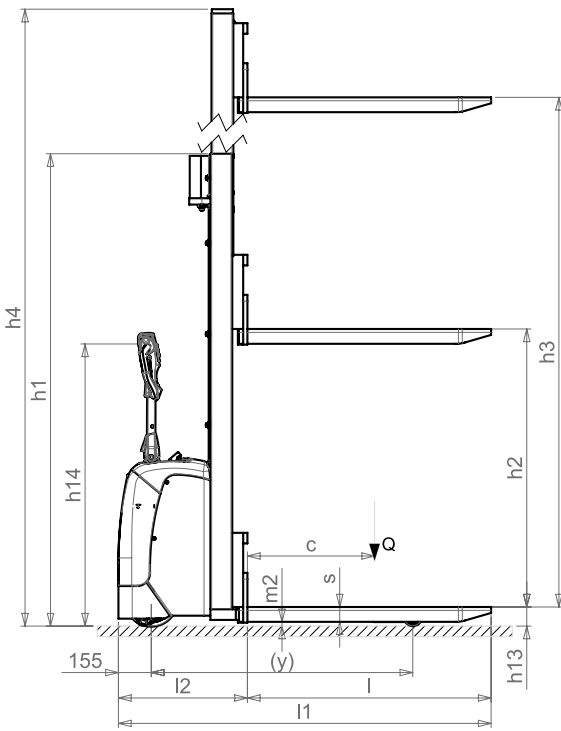

DESCRIPTION										
1.2	MODEL		GX 12/25 BASIC	GX 12/29 BASIC	GX 12/35 BASIC	GX 12/25 EVO	GX 12/29 EVO	GX 12/35 EVO	GX 12/29 EVO FREELIFT	
1.3	DRIVE		ELECTRIC	ELECTRIC	ELECTRIC	ELECTRIC	ELECTRIC	ELECTRIC	ELECTRIC	
1.4	OPERATOR TYPE		PEDESTRIAN	PEDESTRIAN	PEDESTRIAN	PEDESTRIAN	PEDESTRIAN	PEDESTRIAN	PEDESTRIAN	
1.5	LOAD CAPACITY	Q	kg	1200	1200	1200	1200	1200	1200	
1.6	LOAD CENTRE DISTANCE	c	mm	600	600	600	600	600	600	
1.8	LOAD DISTANCE, CENTRE OF DRIVE AXLE TO FORK	x	mm	780	780	780	780	780	780	
1.9	WHEEL BASE	y	mm	1234	1234	1234	1234	1234	1234	
WEIGHTS										
2.1	SERVICE WEIGHT WITH BATTERY (SEE ROW 6.5)		kg	530	545	578	570	585	618	615
2.2	AXLE LOAD LADEN, FRONT/REAR		kg	543/1187	558/1187	591/1187	583/1187	598/1187	631/1187	628/1187
2.3	AXLE LOAD UNLADEN, FRONT/REAR		kg	368/162	383/162	416/162	408/162	423/162	456/162	453/162
TYRES/CHASSIS										
3.1	TYRES			G+P/P	G+P/P	G+P/P	G+P/P	G+P/P	G+P/P	
3.2	TYRE SIZE, FRONT (Ø x width)			250x76	250x76	250x76	250x76	250x76	250x76	
3.3	TYRE SIZE, REAR (Ø x width)			82x70	82x70	82x70	82x70	82x70	82x70	
3.4	SIDE WHEELS (Ø x width)			100x38	100x38	100x38	100x38	100x38	100x38	
3.5	WHEELS, NUMBER (x=DRIVEN) FRONT/REAR			1x+1/2	1x+1/2	1x+1/2	1x+1/2	1x+1/2	1x+1/2	
3.6	TREAD, FRONT	b10	mm	565	565	565	565	565	565	
3.7	TREAD, REAR	b11	mm	410	410	410	410	410	410	
DIMENSIONS										
4.2	HEIGHT, MAST LOWERED	h1	mm	1787	1987	2250	1787	1987	2250	1965
4.3	FREE LIFT	h2	mm	-	-	80	-	-	80	1402
4.4	LIFT	h3	mm	2410	2810	3410	2410	2810	3410	2810
4.5	HEIGHT, MAST EXTENDED	h4	mm	2992	3392	3916	2992	3392	3916	3372
4.6	INITIAL LIFT	h5	mm	-	-	-	-	-	-	-
4.9	HEIGHT OF TILLER IN DRIVE POSITION MIN/MAX	h14	mm	915/1310	915/1310	915/1310	960/1330	960/1330	960/1330	960/1330
4.15	HEIGHT, LOWERED	h13	mm	90	90	90	90	90	90	90
4.19	OVERALL LENGTH	l1	mm	1760	1760	1760	1760	1760	1760	1760
4.20	LENGTH TO FACE OF FORKS	l2	mm	609	609	609	609	609	609	609
4.21	OVERALL WIDTH	b1/b2	mm	800	800	800	800	800	800	800
4.22	FORK DIMENSIONS	s/e/l	mm	70/150/1150	70/150/1150	70/150/1150	70/150/1150	70/150/1150	70/150/1150	70/150/1150
4.24	FORK-CARRIAGE WIDTH	b3	mm	650	650	650	650	650	650	650
4.25	DISTANCE BETWEEN FORK ARMS	b5	mm	560	560	560	560	560	560	560
4.32	GROUND CLEARANCE, CENTRE OF WHEEL BASE	m2	mm	20	20	20	20	20	20	20
4.34	AISLE WIDTH FOR PALLETS 800x1200 LENGTHWISE	Ast	mm	2210	2210	2210	2210	2210	2210	2210
4.35	TURNING RADIUS	Wa	mm	1430	1430	1430	1430	1430	1430	1430
PERFORMANCE DATA										
5.1	TRAVEL SPEED, LADEN/UNLADEN		km/h	4,7/5,2	4,7/5,2	4,7/5,2	4,7/5,2	4,7/5,2	4,7/5,2	
5.2	LIFT SPEED, LADEN/UNLADEN		m/s	0,11/0,19	0,11/0,19	0,11/0,19	0,11/0,19	0,11/0,19	0,10/0,18	
5.3	LOWERING SPEED, LADEN/UNLADEN		m/s	0,12/0,15	0,12/0,15	0,12/0,15	0,25/0,3	0,25/0,3	0,25/0,3	
5.8	MAX GRADEABILITY, LADEN/UNLADEN		%	5/10	5/10	5/10	5/10	5/10	5/10	
5.10	SERVICE BRAKE			ELECTRIC	ELECTRIC	ELECTRIC	ELECTRIC	ELECTRIC	ELECTRIC	
ELECTRIC MOTORS										
6.1	DRIVE MOTOR POWER		kW	0,7	0,7	0,7	0,7	0,7	0,7	
6.2	LIFT MOTOR POWER		kW	2,2	2,2	2,2	2,2	2,2	2,2	
6.4	BATTERY VOLTAGE, NOMINAL CAPACITY C5		V/Ah	24/85 (C20)	24/85 (C20)	24/85 (C20)	24/118 (C5)	24/118 (C5)	24/118 (C5)	
6.5	BATTERY WEIGHT		kg	38	38	38	78	78	78	
6.6	ENERGY CONSUMPTION ACC. TO VDI CYCLE		kWh/h	0,9	0,9	0,9	0,9	0,9	0,9	
8.4	SOUND LEVEL AT DRIVER'S EAR		dB(A)	62	62	62	62	62	62	

# LX

The new LX is a strong and reliable partner which bridges the gap between low-duty and heavy duty material handling daily operations. Due to its durability, low maintenance LX is suitable for environments as logistic centers, terminals, production and manufacturing areas. Also the new tiller arm equipped with fork lifting and lowering proportional control improves user-friendliness and maneuverability of the truck.



Flip down operator platform available  
AC traction motor



**CARTER INTERNAL FEATURES**  
The New LX design with its strong wheel protection guard integrated into the frame structure aimed to increase both stability and safety. Now the new strong ABS battery cover comes with hinges which speed up all ordinary battery maintenance operations.



**TOTAL WIDTH REDUCTION**  
The LX maneuverability has been improved by reduction of total width from 850 mm to 800 mm and by side wheel always within the truck width even when pivoting, allowing the operator to handle goods in narrow spaces and corridors.



**IMPROVED TILLER**  
Improved tiller with lifting/lowering proportional control. Fully integrated system with throttle, safety pushbutton, horn, hourmeter, battery status indicator.



**MAST**  
The wider mast combined with the new ergonomic tiller to make LX more agile and easy to use. A sticker ruler allows the operator to easily check the forks elevation by sight.

# Electric Stackers

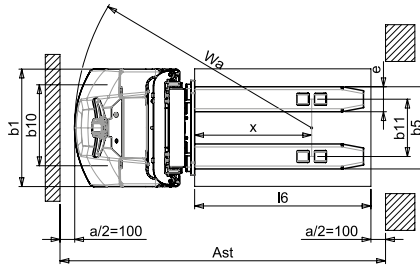
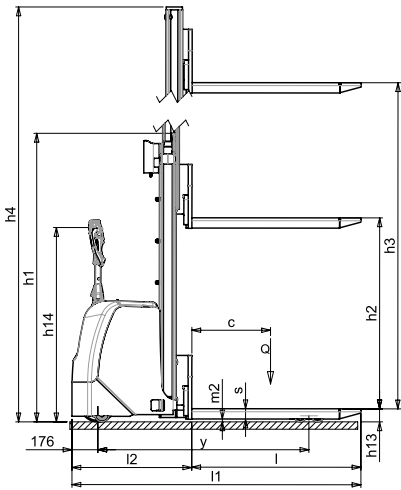

DESCRIPTION		SIMPLEX		DUPLEX		TRIPLEX	
1.2 MODEL		LX 12/16	LX 16/16	LX 12/29	LX 16/29	LX 14/45	LX 14/45 FREELIFT
1.3 DRIVE		ELECTRIC	ELECTRIC	ELECTRIC	ELECTRIC	ELECTRIC	ELECTRIC
1.4 OPERATOR TYPE		PEDESTRIAN	PEDESTRIAN	PEDESTRIAN	PEDESTRIAN	PEDESTRIAN	PEDESTRIAN
1.5 LOAD CAPACITY	Q kg	1200	1400	1200	1600	1400	1400
1.6 LOAD CENTRE DISTANCE	c mm	600	600	600	600	600	600
1.8 LOAD DISTANCE, CENTRE OF DRIVE AXLE TO FORK	x mm	780	797	780	820	797	797
1.9 WHEEL BASE	y mm	1373	1436	1373	1436	1436	1436
<b>WEIGHTS</b>							
2.1 SERVICE WEIGHT WITH BATTERY (SEE LINE 6.5)	kg	768	920	856	1050	1190	1223
2.2 AXLE LOAD LADEN, FRONT/REAR	kg	769/1199	888/1632	803/1253	977/1673	1002/1588	913/1710
2.3 AXLE LOAD UNLADEN, FRONT/REAR	kg	548/220	633/287	612/244	723/315	801/389	823/400
<b>TYRES/CHASSIS</b>							
3.1 TYRES		G+P/P	G+P/P	G+P/P	G+P/P	G+P/P	G+P/P
3.2 TYRE SIZE, FRONT (Ø x width)		250x76	250x101	250x76	250x101	250x101	250x101
3.3 TYRE SIZE, REAR (Ø x width)		82x70	82x70	82x70	82x70	82x70	82x70
3.4 SIDE WHEELS (Ø x width)		2 x 100x38	2 x 100x38	2 x 100x38	2 x 100x38	2 x 100x38	2 x 100x38
3.5 WHEELS, NUMBER (x=DRIVEN) FRONT/REAR		1x+2/4	1x+2/4	1x+2/4	1x+2/4	1x+2/4	1x+2/4
3.6 TREAD, FRONT	b10 mm	586	586	586	586	586	586
3.7 TREAD, REAR	b11 mm	390	390	390	390	390	390
<b>DIMENSIONS</b>							
4.2 HEIGHT, MAST LOWERED	h1 mm	1965	1965	1988	1965	2080	2089
4.3 FREE LIFT	h2 mm	1510	1510	-	-	-	1510
4.4 LIFT	h3 mm	1510	1510	2810	2810	4410	4410
4.5 HEIGHT, MAST EXTENDED	h4 mm	1965	1965	3390	3370	5020	5029
4.6 INITIAL LIFT	h5 mm	-	-	-	-	-	-
4.9 HEIGHT OF TILLER IN DRIVE POSITION MIN/MAX	h14 mm	990/1390	990/1390	990/1390	990/1390	990/1390	990/1390
4.15 HEIGHT, LOWERED	h13 mm	90	90	90	90	90	90
4.19 OVERALL LENGTH	l1 mm	1920	1966	1920	1944	1966	1966
4.20 LENGTH TO FACE OF FORKS	l2 mm	765	816	770	795	816	816
4.21 OVERALL WIDTH	b1 mm	800	800	800	800	800	800
4.22 FORK DIMENSIONS	s/e/l mm	70/150/1150	70/170/1150	70/150/1150	70/170/1150	70/170/1150	70/170/1150
4.24 FORK-CARRIAGE WIDTH	b3 mm	650	644	650	644	644	644
4.25 DISTANCE BETWEEN FORK ARMS	b5 mm	560	560	560	560	560	560
4.32 GROUND CLEARANCE, CENTRE OF WHEEL BASE	m2 mm	20	20	20	20	20	20
4.34 AISLE WIDTH FOR PALLETS 800x1200 LENGTHWISE	Ast mm	2330	2380	2330	2365	2380	2380
4.35 TURNING RADIUS (PLATFORM CLOSED/OPEN)	Wa mm	1550	1613	1550	1613	1613	1613
<b>PERFORMANCE DATA</b>							
5.1 TRAVEL SPEED, LADEN/UNLADEN	km/h	6/6	6/6	6/6	6/6	6/6	6/6
5.2 LIFT SPEED, LADEN/UNLADEN	m/s	0,15/0,28	0,14/0,28	0,15/0,28	0,13/0,25	0,14/0,28	0,14/0,28
5.3 LOWERING SPEED, LADEN/UNLADEN	m/s	0,31/0,16	0,34/0,40	0,31/0,16	0,31/0,38	0,34/0,40	0,34/0,40
5.8 MAX GRADEABILITY, LADEN/UNLADEN	%	5/10	5/10	5/10	5/10	5/10	5/10
5.10 SERVICE BRAKE		ELECTRIC	ELECTRIC	ELECTRIC	ELECTRIC	ELECTRIC	ELECTRIC
<b>ELECTRIC MOTORS</b>							
6.1 DRIVE MOTOR POWER	kW	1.2	1.2	1.2	1.2	1.2	1.2
6.2 LIFT MOTOR POWER	kW	2.2	3.2	2.2	3.2	3.2	3.2
6.4 BATTERY VOLTAGE, NOMINAL CAPACITY C5	V/Ah	24/300	24/300	24/300	24/300	24/300	24/300
6.5 BATTERY WEIGHT	kg	270	270	270	270	270	270

MODEL	DUPLEX					TRIPLEX			
	LX 12/25	LX 12/35	LX 12/38	LX 16/25	LX 16/35	LX 14/42	LX 14/42 FREELIFT	LX 14/50	LX 14/50 FREELIFT
SERVICE WEIGHT WITH BATTERY (SEE LINE 6.5)	841	894	904	1025	1090	1172	1204	1229	1262
AXLE LOAD LADEN, FRONT/REAR	798/1243	817/1277	821/1283	960/1665	1005/1685	883/1689	902/1702	916/1713	935/1727
AXLE LOAD UNLADEN, FRONT/REAR	601/240	639/255	646/258	706/319	750/340	789/383	810/394	827/402	849/413
HEIGHT, MAST LOWERED	h1 mm	1788	2258	2435	1765	2265	1985	2285	2294
FREE LIFT	h2 mm	-	80	80	-	-	1370	-	1675
LIFT	h3 mm	2410	3410	3760	2410	3410	4110	5025	5025
HEIGHT, MAST EXTENDED	h4 mm	2990	3915	4265	2970	3970	4725	5635	5644

BATTERY		
BATTERY VOLTAGE, NOMINAL CAPACITY C5	V/Ah	24/225 24/300
BATTERY WEIGHT	kg	270 270

# STACKERS

Residual lifting capacity - kg

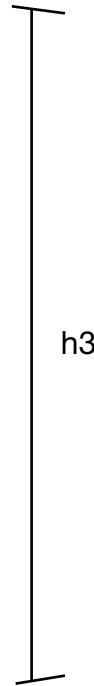

\* H3

MODEL	900	1000	1200	1600	2000	2500	2900	3300	3500	3600	3800	3850	4000	4200	4500	5000
MX 510		500 kg														
MX 516				500 kg												
MX 1016				1000 kg												
TX 10/09	1000 kg															
TX 10/16				1000 kg												
TX 10/20					1000 kg											
TX 12/25						1200 kg										
TX 12/29						1200 kg	800 kg									
TX 12/35						1200 kg	800 kg		600 kg							
TX 10/16 Straddle				1000 kg												
GX 12/25						1200 kg										
GX 12/29						1200 kg	800 kg									
GX 12/29 Free Lift						1200 kg	800 kg									
GX 12/35						1200 kg	800 kg		600 kg							
LX 12/16				1200 kg												
LX 12/25						1200 kg										
LX 12/29						1200 kg	1000 kg									
LX 12/35						1200 kg	1000 kg		800 kg							
LX 12/38						1200 kg	1000 kg		800 kg			800 kg				
LX 14/42								1400 kg		1200 kg			1000 kg	800 kg		
LX 14/45								1400 kg		1200 kg			1000 kg		800 kg	
LX 14/50								1400 kg		1200 kg			1000 kg			800 kg
LX 16/16				1600 kg												
LX 16/25						1600 kg										
LX 16/29						1600 kg	1400 kg									
LX 16/35						1600 kg	1400 kg		1100 kg							
LX 14/42 Free Lift								1400 kg		1200 kg			1000 kg	800 kg		
LX 14/45 Free Lift								1400 kg		1200 kg			1000 kg		800 kg	
LX 14/50 Free Lift								1400 kg		1200 kg			1000 kg			800 kg

\*H3: Lifting height (mm) - Load center at C = 600 mm

Available from

# Systems Design

storage & materials handling equipment

tel +44(0)1892 256007

[www.systemsdesignuk.com](http://www.systemsdesignuk.com)



**PR INDUSTRIAL SRL**

Località Il Piano, 53031 Casole d'Elsa (SI) Italy / Tel. +39 0577 9651, Fax: +39 0577 949076 / [info@pramac.com](mailto:info@pramac.com) / [www.pramac.com](http://www.pramac.com)  
Worldwide Service & Parts Online Center: [www.pramacparts.com](http://www.pramacparts.com)